

# LX-D Analog Shore Durometer

## User's Manual

### Function

LX-D Analog Shore Durometer is an instrument for testing hardness of vulcanized rubber and Plastic products. It carries out National standard GB/T531.1-2008 《Rubber, Vulcanized or thermoplastic -Determination of indentation hardness.part1 : durometer method (shore hardness)》 which equals to ISO7619-1:2004 《International Standard Rubber-Determination of Indentation hardness by means of pocket hardness meters》. Meanwhile, it consults and carries out some regulation in JJG1039-2008 《Model D Shore Durometer Inspection Regulation》. This meter can be installed in the same model test stand and be used in the laboratory to test the standard hardness of rubber or plastic. It can also be held in hand to measure the surface hardness of rubber.

Note: The durometer is used to test hardness of of plastic sample, but testing and adjusting must comply with there gulation of GB/T2918-1998 《Plastic Sample Condition Adjustment and the Standard Environment of Testing》

### Specification(Hardness Unit of Shore D Analog Durometer: HD):

Tip Stroke: 0~2.5mm

Dial Indication: 0~100HD

Available Test Range: 20~90HD

Tip Pressure: F=445HD(mN)

Tip Dimension: SR0.1mm

Accuracy:  $\pm 1$ HD

External Dimension: 115 $\times$ 60 $\times$ 25(mm)

Net Weight: 0.16kg

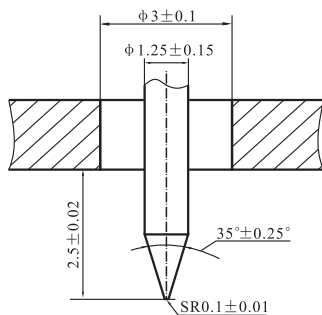

Shore D Analog Durometer

### Operation

First put the tested sample on the stable platform and hold the durometer. The distance between the tip and the sample can not be less than 12mm. Then press it on the sample without any vibrancy and keep the base parallel with the sample's surface, making the tip press the sample vertically. The pressing force should be just enough to make base contacting sample firmly. The reading must be done at regular time, it will be 3 seconds for vulcanized rubber and unknown rubber, 15 seconds for thermoplastic rubber; if adopting other sample time, it should be claimed in test report. Testing 5 times at position of not less than 6mm, and calculate the average.

## Cautions

### 1. Before testing

Before the test, please make sure the needle is pointing to zero . If the needle is not pointing to zero , you can loose the screw on up-right and turn the dial to set the needle. Then press the meter on the testing block and when the tip and base is closely contacted with the block, the needle should point at  $10 \pm 0.5HD$ . If the needle still doesn't point at  $10 \pm 0.5HD$ , press the tip several times slightly to adjust it; if still not point to regular reading, the durometer can not be used.

When the meter is used with Shore Durometer test stand, you can turn the handle and lift the working table to the die poise position, making the tip and base closely contact the glass board. Afterwards, the needle should point at  $10 \pm 0.5HD$ , if not, you can adjust the screw on the working table base.

### 2. Rubber Sample and Temperature(GB/T531.1-2008)

(1). Thickness of the rubber sample should be not less than 6mm, its width is more than 25mm, and its length is more than 50mm. If the thickness is less than 6mm, please use same sample folding together but not more than 3 tier.

(2). The required temperature should be  $23^{\circ}\text{C} \pm 5^{\circ}\text{C}$  and the meter should be kept one hour under this temperature before operation.

### 3. Plastic Sample and Temperature(GB2411-80)

(1). The sample should be square shape with length 50mm and thickness not less than 6mm.

(2). If it is possible, sample should be adjusted in the lab's temperature before being tested in accordance with GB/T2941-1991. The comparing or series test should be done under the same temperature.

4. The surface of rubber and plastic sample should be smooth and even with no damage and dust.

5. Do not advise to convert shore value to international rubber hardness value.

6. Durometer should in accordance with JJG304-2003 to calibrate by calibration organization, Generally, the periods is not more than 1 year .

7. Put the meter into the box and store it in the dry environment to avoid damp.

8. Clean the lift axis and working table base regularly by smearing antirust oil.

9. When using shore D analog durometer, if value is less than 20HD, we suggest to use A model analog shore durometer.

---

制造商：温州山度仪器有限公司

**MANUFACTURER: WENZHOU SUNDOO INSTRUMENTS CO.,LTD**

地址：浙江省温州市龙湾区西台工业区西工西路5号

Add: No.5, Xigongxi Road, Xitai Industrial Zone, Wenzhou China

Zip: 325011

Tel: +86 577 88609905 Fax: +86 577 88390155

Http://www.sundoo.com E-mail: export@sundoo.com

Ver: 2.00 Con: 20170407