

IKA

designed for scientists

MICROSTAR control

ENGLISH

Declaration of conformity

We declare under our sole responsibility that this product corresponds to the regulations 2014/35/EU, 2006/42/EC, 2014/30/EU, 2014/53/EU and 2011/65/EU and conforms with the standards or standardized documents: EN 61010-1, EN 61010-1-2-051, EN 61326-1, EN 60529 and EN ISO 12100.

8

/// DEVICE SETUP

- › MICROSTAR control 8
- › What you should watch out for 9

10

/// SAFETY INSTRUCTIONS

- › Explication of warning symbols 10
- › General information 11
- › Device setup 12
- › Working with the device 13
- › Accessories 15
- › Switch on / off the device 15
- › Disposal 15

16

/// CORRECT USE

- › Basics 16

17

/// UNPACKING

- › Scope of Delivery 17

19

/// USEFUL INFORMATION

- › Stirrer 19

19

/// SPEED

- › Speed – normal operation 19
- › Speed – overload operation 19
- › Output shaft 20

21

/// OPERATOR PANEL AND DISPLAY

- › Operation 21
- › Explanation of symbols on the display 22

24

/// ASSEMBLY

- › Assembling the extension arm to the overhead stirrer 24
- › Assembling the overhead stirrer to the stand 25
- › Assembling the stirring element using the chuck 25
- › Assembling the stirring shaft protector 26
- › Assembling the mixing vessel to the stand 26

27

/// COMMISSIONING

- › Switching on 27
- › Setting the timer 28
- › Calibration 30

32

/// INTERFACES AND OUTPUTS

- › USB interface 32
- › Installation 32
- › Command syntax and format 33

35

/// MAINTENANCE AND CLEANING

- › Cleaning 35
- › Spare parts order 35
- › Repair 36

36

/// ERROR CODES

- › Troubleshooting correctly 36

38

/// WARRANTY

- › Regulations 38

38

/// ACCESSORIES

- › An overview 38

39

/// PERMITTED IKA STIRRER TOOLS

- › An overview 39

40

/// TECHNICAL DATA

- › MICROSTAR control in detail 40

Device setup

/// MICROSTAR control



1	Operator panel and display
2	Chuck
3	Extension arm
4	Temperature sensor socket
5	Power socket
6	USB interface
7	Stirring shaft cap

/// What you should watch out for



Attention! (X)

Safety instructions

/// Explication of warning symbols



Indicates an (extremely) hazardous situation, which, if not avoided, **will result in death, serious injury.**



Indicates a hazardous situation, which, if not avoided, **can result in death, serious injury.**



Indicates a potentially hazardous situation, which, if not avoided, **can result in injury.**



Indicates practices which, if not avoided, **can result in equipment damage.**

/// General information

- › **Read the operating instructions in full before starting up and follow the safety instructions.**
- › Keep the operating instructions in a place where it can be accessed by everyone.
- › Ensure that only trained staff work with the device.
- › Follow the safety instructions, guidelines, occupational health and safety and accident prevention regulations.

Danger! (X)

Please pay attention to the dangerous parts of the equipment in device setup. Beware of the risk of:

- › flammable materials
- › glass breakage as a result of mechanical stirring power

Caution! (X)

Wear your personal protective equipment in accordance with the hazard category of the medium to be processed, there is a risk of:

- › splashing of liquids
- › projectile parts
- › body parts, hair, clothing and jewelry getting caught

The device must only be used in a technically perfect condition.

/// Device setup

Danger! (X)

Users must make sure that the **OFF switch** of the IKA device can be accessed immediately, directly and without risk at any time. If installation or positioning cannot ensure this access at all times, an additional **EMERGENCY STOP** switch that can be easily accessed must be installed in the work area.

Warning! (!)

Ensure stable assembly. The vessel used for stirring must be secured. Use stirring shaft protective equipment!

- › **Set up the stand in a spacious area on an even, stable, clean, non-slip, dry and fireproof surface.**
- › **Remove the chuck key from the chuck before turning on the device.**

- › Place the power supply outside the working area of the device.
- › Avoid knocking and impacting on the lower end of the shaft and the chuck gear teeth. Even minor, invisible damage can lead to imbalance and uneven shaft action.
- › All screw connections must be properly tightened.
- › The high torque developed by the device requires particular care in the choice of stand, cross sleeve and anti-rotation element for the agitating vessel.

/// Working with the device

Danger! (X)

Do not operate the device in explosive atmospheres, with hazardous substances or under water. The device is not explosion – proof it does not meet any Class / Division or Zone explosion protection standards.

- › The device is not suitable for hand-held operation.
- › Do not touch rotating parts during operation!

Warning! (!)

Pathogenic materials must only be processed in closed vessels under a suitable fume hood. If you have any questions, please contact IKA application support.

The operation of a free rotating shaft end is prohibited. Therefore, for safety reason, only insert through the stirring tool over the upper edge of housing at standstill.

Caution! (⚠)

Make certain that the unit is set at the lowest speed before commissioning; otherwise, the unit will begin running at the speed set in last operation. Gradually increase the speed. Please observe the max. permitted speed for the stirring element. Never set higher speed.

Covers or parts that can be removed from the device without tools must later be refitted to ensure safe operation. This will prevent the infiltration of foreign objects, liquids and other contaminants.

- › Imbalance of the output shaft, the chuck and in particular the stirring tools can lead to uncontrolled resonant vibrational behavior of the device and the whole assembly. Glass apparatus and stirrer containers can be damaged or shattered by this. It can cause injury to the operator, also can damage the rotating stirring tool. In this case exchange the stirring tool for one without imbalance or remedy the cause of the imbalance. If there is still imbalance, return it to the dealer or the manufacturer along with a description of the fault.
- › There may be electrostatic activity between the medium and the output shaft which could cause a direct danger.
- › Never operate the device with the stirrer tools rotating freely. Ensure that parts of the body, hair, jewelry or items of clothing cannot be trapped by the rotating parts.
- › Pay attention when setting the speed to any imbalance of the stirrer tools and possible spraying of the medium to be stirred.
- › Ensure that the stand does not start to move.
- › Only process media that will not react dangerously to the extra energy produced through processing. This also applies to any extra energy produced in other ways, e.g. through light irradiation.

Reduce the speed if:

- › the medium splashes out of the vessel because the speed is too high,
- › the device is not running smoothly,
- › the device begins to move around because of dynamic forces,
- › an error occurs.

/// Accessories

- › Protect the device and accessories from bumping and impacting.
- › Check the device and accessories beforehand for damage each time when you use them. Do not use damaged components.
- › Safe operation is only guaranteed with the accessories described in the "Accessories" section.
- › Must disconnect the power before changing stirring element and fitting allowed accessories.

/// Switch on / off the device

If the device is operated too long in overload or if the ambient temperature is too high, the device switches off permanently.

- › Disconnecting the device from the power outlet only works by removing the main cord from the socket.
- › The device must only be operated with the original power supply unit.
- › The power supply comes with interchangeable plug adapters for different countries so make sure the appropriate adapter is used.
- › The outlet for the power supply must be easily accessible.
- › After an interruption in the power supply during a stirring process, the device does not restart automatically.
- › The device must only be opened by trained technicians, even during repair. The device must be unplugged from the power supply before opening. Live parts inside the device may still be live for some time after unplugging from the power supply.

/// Disposal

The device must be disposed of in accordance with national regulations.

Correct use

/// Basics

Use

- › For mixing / stirring liquids from low to medium viscosities with various stirring tools.
- › **Stand device** (chuck points down)

Range of use (indoor use only)

- › Laboratories
- › Pharmacies
- › Universities
- › Schools

The safety of the user cannot be guaranteed:

- › if the device is operated with accessories that are not supplied or recommended by the manufacturer.
- › if the device is operated improperly or contrary to the manufacturer's specifications.
- › if the device or the printed circuit board are modified by third parties.

Unpacking

/// Scope of Delivery

Unpack the device carefully. **Any damage should be notified immediately to the shipping agent (post office, railway network or logistics company).**

Scope of Delivery

- › MICROSTAR overhead stirrer
- › power supply (with exchangeable adapters)
- › extension arm
- › hexagonal socket screw
- › hexagon socket offset screw key
- › shaft protector R 300 (with 2 fasten screws)
- › chuck key
- › USB cable
- › **H 67.60** temperature sensor
- › user guide
- › warranty card

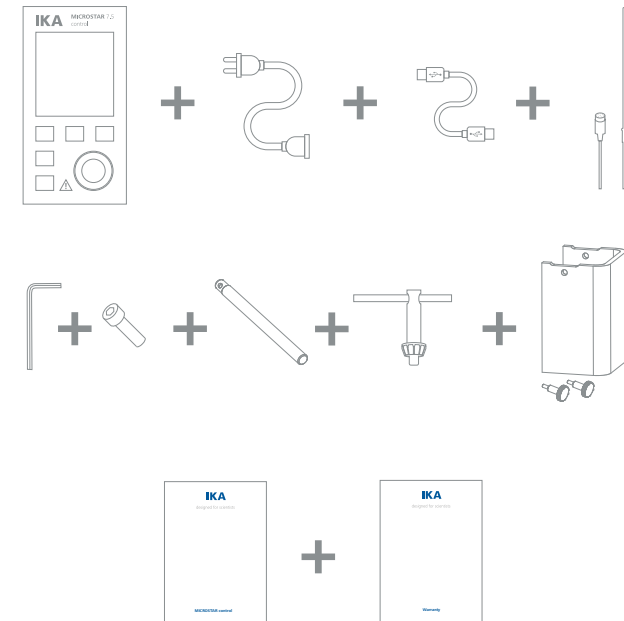

Power supply unit (with exchangeable adapters)

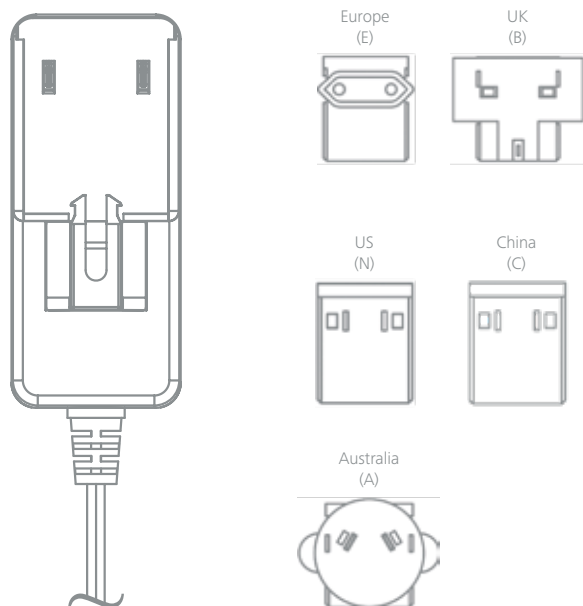

Schematics of device and power supply.

Useful information

/// Stirrer

The stirring device is suitable for continuous operation. The motor current is limited electronically. The device has an anti-stall and anti-overload system. If a fault occurs, a safety circuit immediately switches off the motor permanently. The device starts with the last settings made. If the device vibrates too much, an error message appears on the display and an acoustic signal sound (see chapter "Error codes").

Speed

/// Speed – normal operation

Speed - regulated (no variation in speed):

The speed is monitored and regulated by processor controlled. The target speed is constantly compared with the actual rotation speed value of the output shaft and variations corrected. This guarantees a constant speed even if the viscosity of the substance being stirred changes.

Fluctuations in mains voltage within the permitted tolerance range have no effect on the quality of regulation and constancy of speed.

The speed is set using the front knob. During normal operations the speed value on the display corresponds to the speed of the output shaft in revolutions per minute (rpm).

/// Speed – overload operation

When solid or semi-viscous substances are added, the stirrer can be run for a brief period at 130% its rated power. When running in the overload range (for instance if the viscosity has increased at a particular stage of the process) the speed will reduce to a degree sufficient to keep the torque on the stirrer shaft within the rated torque of the device.

Overload status 1

The device is already running within the overload range, however, the actual speed does not match the set speed. This condition is maintained as long as neither the motor current nor the device temperature exceeds their permissible limit value. In this overload status the torque value flashes.

Overload status 2

The device stop at a load above 130 % of the nominal torque.
Message in the display (see "Error codes" section).

/// Output shaft

Caution! (⚠)

Please see section "Safety instructions"!

The clamping chuck and output shaft permit clamping IKA recommend stirrer tools (see section "Permitted IKA Stirrer tools"). The output shaft is designed as a hollow shaft and the opening on the top side of the housing is closed with a plastic cover. When the stirrer cover is opened, it is possible for stirring shaft to be pushed out over the top edge of the housing at standstill, e.g. during changing container.

For safety reason, the stirrer cover must be pushed back into the opening of the housing so that it is properly closed. This is the only way to ensure that working with the unit is safe and that media cannot enter the device.

Operator panel and display

/// Operation



Display

A	Standby key	Device switches on / enters standby (no disconnection from the power supply network).
B	Lock key	Lock / unlock keys and knob.
C	Vibration monitoring	Activate / deactivate the internal vibration sensor. Set individual levels (I/II/III).
D	Timer key	Activate the timer value adjusting function. Switch between temperature unit °C and °F.
E	Display	Display information as settings.
F	"Counter / Timer" key	Select between "Counter" and "Timer" (stirring function is not active). With a temperature sensor inserted, the torque or temperature display can be selected during operation.
G	Control knob (rotating/pressing)	Set the speed by rotating. Start / stop the stirrer function by pressing. Set the timer by rotating.

/// Explanation of symbols on the display

The symbols appear on the screen change depending on the status and settings of the device. The following screen shows the most significant symbols.

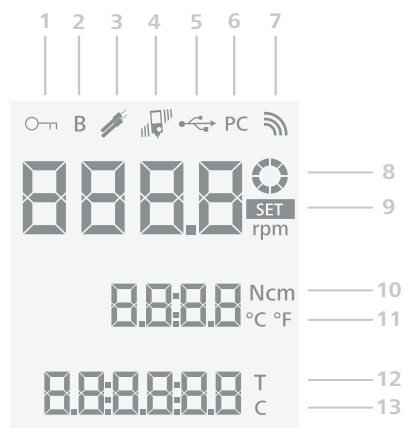

Display

1	This symbol indicates all function keys except for the standby key (A) are locked.
2	This symbol indicates the operating mode.
3	This symbol appears when the temperature sensor is plugged in.
4	This symbol indicates the active vibration recognition and the set sensitivity level.
5	This symbol means the device is communicating via a USB cable.
6	This symbol means the device is connected to a computer and the stirrer is being controlled via labworldsoft.
7	This symbol means the device is communicating with a Wireless Controller or a PC via Bluetooth. The symbol no longer appears if no Bluetooth communication is being performed.
8	This symbol means the stirring function is activated and the device is running.
9	This symbol means the set value for the speed.
10	While the device is running, you can reset the current torque to 0 Ncm by touching the timer key (D) and simultaneously pressing the rotary / push knob (G). Touching the Counter / Timer key (F) switches between the torque and temperature display.
11	The symbol appears only when the temperature sensor is connected. The unit can be switched between Fahrenheit degree (°F) and Celsius degree (°C) by touching timer key (D) when the temperature sensor is connected.
12	This symbol means the timer function is activated.
13	This symbol means the counter function is activated.

Assembly

/// Assembling the extension arm to the overhead stirrer

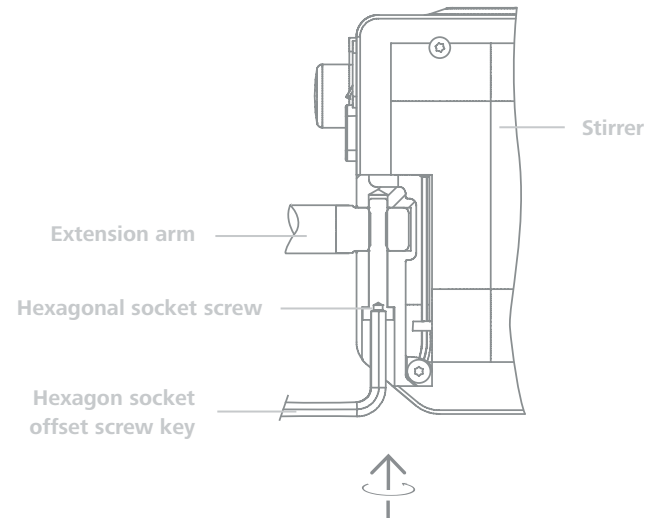

Ensure that the extension arm is fitted securely. Vibration may cause the screw to become loose. It is therefore necessary for safe use to regularly check that the extension arm is attached securely. Tighten the hexagonal bolt as required.

/// Assembling the overhead stirrer to the stand

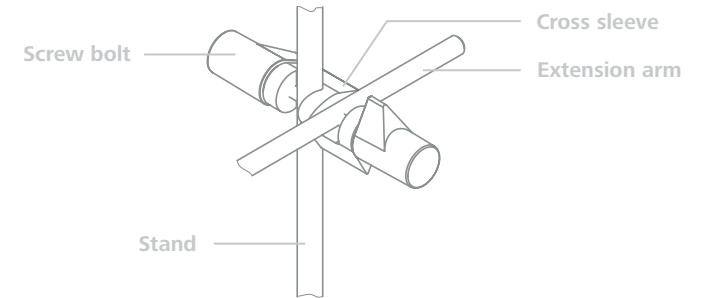

Check that the stirrer is held in position firmly prior to each use and also at regular intervals. The position of the stirrer must only be adjusted when the equipment is stationary and the power supply is disconnected.

/// Assembling the stirring element using the chuck

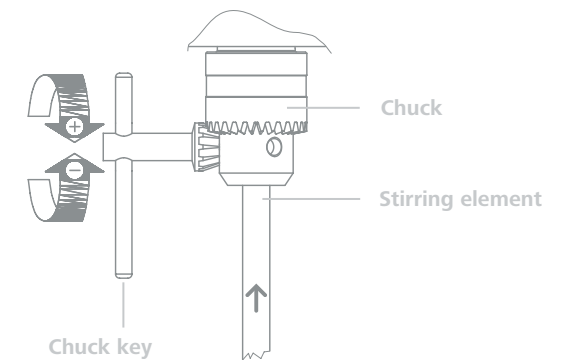

Warning! (!)

The stirring element must only be changed when the equipment is stationary and the power supply is disconnected.

/// Assembling the stirring shaft protector

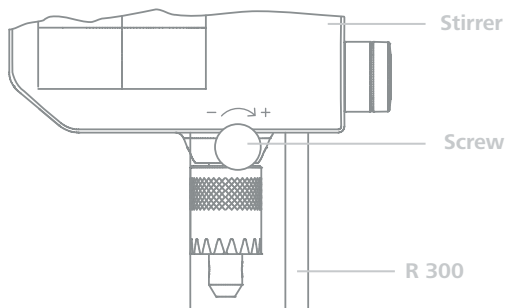

/// Securing the mixing vessel to the stand



Commissioning

/// Switching on

Secure the device to a stable stand with a cross sleeve.

The stirring vessel must always be securely fixed for safety reasons. You must also ensure that the mounting device (stand) is set up in such a way that it is not liable to topple and does not start to move during the stirring procedure. If these conditions have been met, the machine is ready for operation when the mains plug is plugged in. If these conditions are not met, safe operation is not guaranteed and the machine could be damaged. Observe the ambient conditions (temperature, humidity, etc.) listed under "Technical Data".

The AC adapter is suitable for 100 VAC to 240 VAC.

The exchangeable adapter for the relevant country must be attached before the AC adapter is plugged into the mains socket.

Switching on

1. After connecting the power to the device and touching the Standby key (A), the device is switched on. Following screens appear during self test:

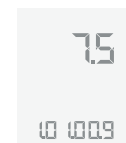

Nominal torque



Software version

2. After that, the following screen appears automatically.



3. Then, the device enters standby status and is ready for operation.

Setting speed

- › Ensure the speed set is suitable for the test medium selected. If in doubt, set the speed to the lowest speed (counterclockwise direction) by rotating the control knob **(G)**. Press the control knob **(G)** to start or stop the stirring.

Setting the vibration monitoring

- › By touching the vibration monitoring key **(C)** you can switch the sensitivity function on/off and set the levels **I, II** or **III**.

Setting the counter

- › As soon as the stirring function starts, the counter function is automatically activated.

/// Setting the timer (hh:mm:ss)

The counter is deactivated.

Procedure:

1. Select the Counter / Timer key **(F)**.
2. Select timer key **(D)** and edit timer:
 - › Turn control knob **(G)**: Setting the value.
 - › Pressing the control knob **(G)**: Confirms the set value and switches to the next value (hh:mm:ss).

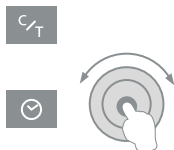

Locking the keys and knob

By touching the lock key **(B)** about 2 seconds, you can lock the control elements of the device. Thus, no accidental changes are possible during operation. By touching the lock key **(B)** about 2 seconds again, the control elements are unlocked.

When the keys and rotary knob are locked by touching the lock / unlock key (B), you can still switch off the device by touching the standby key (A). After restarting the device, the lock function is disabled.

Torque reset to zero

Keys combination during operation:

- › Touch and hold the timer key **(D)**.
- › Pressing the control knob **(G)** resets the current torque to 0 Ncm.



/// Calibration

Notice! (!)

Stirring tool must be removed from the chuck! In calibration mode the chuck rotates up to max. speed.

The setting functions can be exited at any time by touching the standby key (A).

Switch off the device using the standby key (A) and follow the steps below:

1. Pressing and hold down the control knob (G).
› Touching the standby key (A) takes you to the additional functions.



Edit **Bluetooth**:

- › Rotating the control knob (G) you can select between "on / off".
- › Pressing the control knob confirms the entry and takes you to the next function.



2. Edit Beep:

- › Rotating the control knob (G) you can select between "on / off".
- › Pressing the button confirms the entry and takes you to the next function.

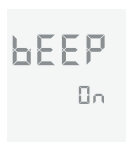

3. **Torque calibration:**

- › Pressing the control knob (G) starts the torque calibration.



Warning! (!)

The chuck rotates up to maximum speed! Do not touch rotating parts!

During torque calibration the device can be stopped by pressing the control knob (G). The device stops the calibration and returns to the working screen.

The torque calibration is ended when the max. speed is reached. The working screen appears and the device is ready for operation.

Interfaces and outputs

/// USB interface

The device can be connected to a PC and operated with the laboratory software labworldsoft through USB interface.

Please comply with the system requirements together with the operating instructions and help section included with the software.

The Universal Serial Bus (USB) is a serial bus for connecting the device to the PC. Devices equipped with USB can be connected to a PC during operation (hot plugging). Connected devices and their properties are automatically recognized. Use the USB interface in conjunction with labworldsoft for operation in „Remote“ mode and also to update the firmware.

/// Installation

First, download the latest driver for IKA devices with USB interface from: <http://www.ika.com/ika/lws/download/usb-driver.zip>. Install the driver by running the setup file. Then connect the IKA device through the USB data cable to the PC. The data communication is via a virtual COM port.

/// Command syntax and format

The following applies to the command set:

- › Commands are generally sent from the computer (Master) to the stirrer machine (Slave).
- › The stirrer machine sends only at the computer's request. Even fault indications cannot be sent spontaneously from the stirrer machine to the computer (automation system).
- › Commands are transmitted in capital letters.
- › Commands and parameters including successive parameters are separated by at least one space (Code: 0 × 20).
- › Each individual command (incl. parameters and data) and each response are terminated with Blank CR LF (Code: 0 × 20 0 × 0d 0 × 20 0 × 0A) and have a maximum length of 80 characters.
- › The decimal separator in a number is a dot (Code: 0 × 2E).

The above details correspond as far as possible to the recommendations of the NAMUR working party (NAMUR recommendations for the design of electrical plug connections for analogue and digital signal transmission on individual items of laboratory control equipment, rev. 1.1).

The NAMUR commands and the additional specific IKA commands serve only as low level commands for communication between the stirrer machine and the PC. With a suitable terminal or communications programme these commands can be transmitted directly to the stirrer equipment. The IKA software package, labworldsoft, provides a convenient tool for controlling stirring equipment and collecting data under MS Windows, and includes graphical entry features, for motor speed ramps for example.

Commands	Function
IN_NAME	Read device name
IN_PV_3	Read PT1000 value
IN_PV_4	Read current speed value
IN_PV_5	Read current torque value
IN_SP_4	Read rated speed value
IN_SP_5	Read the torque limit value
IN_SP_6	Read the speed limit value
IN_SP_8	Read the safety speed value
OUT_SP_4	Adjust the rated speed value
OUT_SP_5	Adjust the torque limit value
OUT_SP_6	Adjust the speed limit value
OUT_SP_8	Adjust the safety speed value
START_4	Start the motor
STOP_4	Stop the motor
RESET	Switch to normal operating mode
OUT_MODE_n (n= 1 or 2)	Change the direction of rotation
IN_MODE	Read the direction of rotation

Maintenance and cleaning

/// Cleaning

The device is maintenance-free. It is only subject to the natural wear and tear of components and their statistical failure rate.

For cleaning disconnect the main plug!

Use only cleaning agents which have been approved by IKA to clean IKA devices.

Dirt	Cleaning agent
Dye	isopropyl alcohol
Construction material	water containing tenside / isopropyl alcohol
Cosmetics	water containing tenside / isopropyl alcohol
Foodstuffs	water containing tenside
Fuel	water containing tenside

For materials which are not listed, please request information from IKA application support. Wear protective gloves during cleaning the devices. Electrical devices may not be placed in the cleansing agent for the purpose of cleaning. Do not allow moisture to get into the device when cleaning. Before using another than the recommended method for cleaning or decontamination, the user must ascertain with IKA that this method does not destroy the device.

/// Spare parts order

When ordering spare parts, please give:

- › machine type
- › serial number, see type plate
- › item and designation of the spare part,
see www.ika.com, spare parts diagram and spare parts list
- › software version

/// Repair

Please send in device for repair only after it has been cleaned and is free from any materials which may constitute a health hazard.

For repair, please request the "Decontamination Certificate" form from IKA or download a print version from www.ika.com.

If you require servicing, return the device in its original packaging. Storage packaging is not sufficient. Please also use suitable transport packaging.

Error codes

/// Troubleshooting correctly

If an error occurs, the fault is shown by an error code on the screen.

Proceed as follows in such cases:

- › Disconnect the device from the power supply.
- › Carry out corrective measures.
- › Restart device.

Error code | Cause | Effect | Solution

Err. 02

Cause	› hardware driving error
Effect	› motor off
Solution	› contact the service department

Err. 03

Cause	› temperature inside of the device is too high
Effect	› motor off
Solution	› switch off the device and allow it cool down

Err. 04

Cause	› motor blockage or overload
Effect	› motor off
Solutions	› disconnect the device from the power supply › decrease the load on the motor and restart device again

Err. 05

Cause	› vibration of the device is higher than the permitted value
Effect	› motor off
Solutions	› disable the vibration detection › Make adjustments to correct the conditions causing the excessive vibrations.

Err. 06

Cause	› the device fall from assembly
Effect	› motor off
Solutions	› disconnect the device from the power supply › secure the device to the stand correctly

Err. 08

Cause	› speed sensor fault or overload
Effect	› motor off
Solution	› disconnect the device from the power supply

If the actions described fails to resolve the fault or another error code is displayed then take one of the following steps:

- › Contact the service department.
- › Send the device for repair, including a short description of the fault.

Warranty

/// Regulations

In accordance with IKA warranty conditions, the warranty period is 24 months. For claims under the warranty please contact your local dealer. You may also send the machine direct to our factory, enclosing the delivery invoice and giving reasons for the claim. You will be liable for freight costs.

The warranty does not cover worn out parts, nor does it apply to faults resulting from improper use, insufficient care or maintenance not carried out in accordance with the instructions in this operating manual.

Accessories

/// An overview

General accessories

- › **R 1825** Plate stand
- › **R 1826** Plate stand
- › **R 1827** Plate stand
- › **R 182** Cross sleeve
- › **RH 3** Strap clamp
- › **R 300** Stirring shaft protection (with 2 screws)
- › **FK 1** Flexible coupling
- › **H 67.60** Temperature sensor
- › **H 67.61** Temperature sensor
- › **H 70** Extension cable
- › **H 62.51** Stainless steel sensor
- › **H 66.51** Stainless steel sensor, glass-coated
- › **USB 2.0 cable A – micro B**

See more accessories on www.ika.com.

Permitted IKA stirrer tools

/// An overview

Propeller stirrer

- › **R 1342** max. speed (rpm) ≤ 2,000
- › **R 1381** max. speed (rpm) ≤ 2,000
- › **R 1382** max. speed (rpm) ≤ 2,000

Propeller stirrer, PTFE

- › **R 1389** max. speed (rpm) ≤ 800

Turbine stirrer

- › **R 1311** max. speed (rpm) ≤ 2,000
- › **R 1312** max. speed (rpm) ≤ 2,000

Dissolver stirrer

- › **R 1300** max. speed (rpm) ≤ 2,000
- › **R 1303** max. speed (rpm) ≤ 2,000

Centrifugal stirrer

- › **R 1352** max. speed (rpm) ≤ 2,000

Anchor stirrer

- › **R 1330** max. speed (rpm) ≤ 1,000

Technical data

/// MICROSTAR control in detail

Technical data MICROSTAR control

	MICROSTAR 7.5 control 15 control 30 control		
Speed range under nominal load	0 / 30 – 2.000 rpm	0 / 30 – 1.000 rpm	0 / 30 – 500 rpm
Speed adjustment	Stepless		
Speed display	LCD		
Speed setting accuracy	± 1 rpm		
Speed measurement deviation	Speed < 300 rpm: ± 3 rpm Speed > 300 rpm: ± 1 %		
Max. torque at stirrer shaft	7,5 Ncm	15 Ncm	30 Ncm
Deviation of torque measurement	± 3 Ncm		
Max. stirring quantity (water)	5 l	10 l	20 l
Max. viscosity	4.000 mPa·s	8.000 mPa·s	20.000 mPa·s
Port for external temperature sensor	yes		
Temperature measurement resolution	0,1 K		
Temperature measurement range	-10 – 350 °C		
Limiting deviation temperature sensor Pt 1000 EN 60751 class A	≤ ± (0,15 + 0,002 × ITI)		
Temperature measurement accuracy	± 0,5 + tolerance PT 1000 (DIN EN 60751 class A)		
Timer / counter function	yes		
Interface	USB		
Permitted on time	100 %		
Nominal voltage	24 VDC		
Max. current	1.300 mA		
Max. input power	32 W		

	MICROSTAR 7.5 control 15 control 30 control		
Max. output power at stirring shaft	15,7 W		
Protection class acc. to EN 60529	IP 54		
Contamination level	2		
Protection at overload	motor current limitation		
Ambient temperature	5 – 40 °C		
Ambient humidity (rel.)	80 %		
Drive	Brushless DC-Motor		
Clamping chuck-clamping range	0,5 – 8 mm		
Hollow shaft internal diameter	8,5 mm		
Extension arm (Ø × L)	13 × 160 mm		
Dimensions (W × D × H) (without extension arm)	60 × 136 × 173 mm		
Weight (with extension arm and clamping chuck)	1,18 kg	1,26 kg	1,26 kg
Operation at a terrestrial altitude	max. 2.000 m		

Power supply

	100 – 240 VAC
	1 A
Input	50 – 60 Hz
	24
Output	36W LPS (Limited Power Source)
Protection class	II (double insulated)



designed for scientists

IKA-Werke GmbH & Co. KG

Janke & Kunkel-Straße 10, 79219 Staufen, Germany
Phone: +49 7633 831-0, Fax: +49 7633 831-98
eMail: sales@ika.de

USA

IKA Works, Inc.
Phone: +1 910 452-7059
eMail: sales@ika.net

KOREA

IKA Korea Ltd.
Phone: +82 2 2136 6800
eMail: info@ika.kr

BRAZIL

IKA Brasil
Phone: +55 19 3772 9600
eMail: sales@ika.net.br

MALAYSIA

IKA Works (Asia) Sdn Bhd
Phone: +60 3 6099-5666
eMail: sales.lab@ika.my

CHINA

IKA Works Guangzhou
Phone: +86 20 8222 6771
eMail: info@ika.cn

POLAND

IKA Poland Sp. z o.o.
Phone: +48 22 201 99 79
eMail: sales.poland@ika.com

JAPAN

IKA Japan K.K.
Phone: +81 6 6730 6781
eMail: info_japan@ika.ne.jp

INDIA

IKA India Private Limited
Phone: +91 80 26253 900
eMail: info@ika.in

ENGLAND

IKA England LTD.
Phone: +44 1865 986 162
eMail: sales.english@ika.com

Discover and order the fascinating products of IKA online:

www.ika.com



Technical specifications may be changed without prior notice.