

HV-G series HW-G series

INSTRUCTION MANUAL

Digital Platform Scale

HV-15KGL
HV-60KGL
HV-200KGL

HV-15KGV
HV-60KGV
HV-200KGV

HW-10KGL
HW-60KGL
HW-100KGL
HW-200KGL

HW-10KGV
HW-60KGV
HW-100KGV
HW-200KGV

HW-300KGL4
HW-600KGL4
HW-600KGL3
HW-1200KGL3

HW-300KGV4
HW-600KGV4
HW-600KGV3
HW-1200KGV3

A&D

A&D Company, Limited



This is a hazard alert mark.



This mark informs you about the operation of the product.

Note This manual is subject to change without notice at any time to improve the product. No part of this manual may be photocopied, reproduced, or translated into another language without the prior written consent of A&D Company, Limited.

Product specifications are subject to change without any obligation on the part of the manufacturer.

Copyright©2002 A&D Company, Limited



Contents

1.	Compliance	3
1.1.	Compliance with FCC rules.....	3
2.	Outline and Features	4
3.	Unpacking	5
3.1.	Accessories and Options List.....	7
4.	Precautions	9
4.1.	Installing the Scale	9
4.2.	Operating the Scale	9
4.3.	Storing the Scale	9
5.	Installing the Scale	10
5.1.	Setting up the Scale	10
5.1.1.	Procedure A	10
5.1.2.	Procedure B	11
5.1.3.	Procedure C	12
5.2.	Installing the Batteries for Type L	13
5.3.	Removing the Pole	14
5.3.1.	Procedure A	14
5.3.2.	Procedure B	15
5.4.	Grounding the scale	16
6.	Description of Each Part	17
6.1.	Display and Symbols	19
6.2.	Keys	21
7.	Basic Operation	23
7.1.	Turning the Scale on/off and Weighing	23
7.1.1.	Type V or Type L with AC Adapter	23
7.1.2.	Type L with Batteries	24
7.2.	Tare (And Net Display)	25
7.2.1.	Tare Input by Weighing	25
7.2.2.	Digital Input (Preset Tare)	25
7.3.	Weighing Range for the HV-G Series	26
7.4.	Mode Key (Changing Unit and Mode)	27
8.	Counting Mode	29
8.1.	Storing a Unit Mass	29
8.2.	Counting the Number of Articles	30
9.	Percentage Mode	31
9.1.	Storing a 100% Mass	31
9.2.	Reading the Percentage	32
10.	Accumulation Function	33
10.1.	Preparation (Setting Parameters)	34
10.2.	Operation and Performance (Examples)	35

11.	Upper/Lower Comparator Function.....	36
11.1.	Preparation (Setting Parameters)	37
11.2.	Operation and Performance (Examples).....	39
12.	Full/Dribble Batch Function.....	40
12.1.	Preparation (Setting Parameters)	42
13.	Simple Batch Function.....	44
13.1.	Preparation (Setting Parameters)	45
13.2.	Operation and Performance (Examples).....	46
14.	Calibration (Adjusting the Scale).....	47
14.1.	Gravity Acceleration Table.....	48
14.2.	Complete Calibration Procedure	49
14.2.1.	Gravity Acceleration Correction	49
14.2.2.	Preparation	49
14.2.3.	Calibration of the Zero Point	50
14.2.4.	Span Calibration	50
15.	Function Table	51
15.1.	Parameter Setting Procedure.....	51
15.2.	Parameter List.....	52
16.	RS-232C Serial Interface.....	56
16.1.	Data Format	57
16.2.	Stream Mode.....	59
16.2.1.	Preparation and Performance (Examples).....	59
16.3.	Command Mode	60
16.3.1.	Command List.....	60
16.3.2.	Example of Setting Parameters	63
17.	Options	64
17.1.	Extension Load Cell Cable (OP-02)	64
17.2.	RS-232C/ Relay Output/ Buzzer (OP-03)	66
17.3.	RS-422/ RS-485 / Relay Output (OP-04)	68
17.3.1.	Communication Format.....	71
17.3.2.	Command List.....	71
17.4.	Built-in Printer for Type V (OP-06)	74
18.	Specifications	76
19.	Maintenance	81
19.1.	Check Points Before Calling Maintenance Service	81
19.1.1.	Repair	81



1. Compliance



1.1. Compliance with FCC rules

- Please note that this equipment generates, uses and can radiate radio frequency energy. This equipment has been tested and has been found to comply with the limits of a Class A computing device pursuant to Subpart J of Part 15 of FCC rules. These rules are designed to provide reasonable protection against interference when this equipment is operated in a commercial environment. If this unit is operated in a residential area it might cause some interference and under these circumstances the user would be required to take, at his own expense, whatever measures are necessary to eliminate the interference.

(FCC = Federal Communications Commission in the U.S.A.)



2. Outline and Features

- The HV-G series are platform scales with 1/3000 resolution, and have the triple weighing range function to select the weighing range.
- The HW-G series come with two types of resolution;
1/6000 : HW-300KGL4, HW-300KGV4, HW-600KGL4, HW-600KGV4, HW-600KGL3,
HW-600KGV3, HW-1200KGL3 and HW-1200KGV3.
1/10000 : Other models
- Type L scales use a Liquid Crystal Display (LCD) and use batteries or an AC adapter as a power source.
- Type V scales use a fluorescent display so it can be read in dim light. This type is directly powered from the AC power line.
- Using the standard RS-232C serial interface, data can be output to a printer, and the scale can be controlled or can be set by a command from a personal computer.
- The counting mode converts the total mass value (total weight) of articles to be counted, to a count, when each article has the same mass value.
- The scales can display the unit of percentage.
- The accumulation function (up to 6 digits) accumulates each weight value and counts the number of times articles are weighed.
- The comparator function compares the displayed weight value with the upper limit value (HI) and the lower limit value (LO) and displays the result. The result can be output by a buzzer if option OP-03 is installed.
- The simple batch function or full/dribble batch function can be used for filling up to a target mass value. The status of a weight value can be output if option OP-03 or OP-04 is installed. The outputs are zero band, preliminary and final.
- The optional RS-422/RS-485 serial interface can control up to 16 scales from a computer, when this option (OP-04) is installed instead of an RS-232C serial interface.
- Type V scales can be equipped with option OP-06, a built-in impact dot matrix printer.
- The following parameters are stored in the scale even if the power is removed.

Unit mass of counting mode
100% mass of percentage mode
Total count and total mass of accumulation function
Upper limit value and lower limit value of upper / lower comparator function, Final value, preliminary value and zero band of full / dribble batch function or Final value, preliminary value and zero band of simple batch function
Calibration data
Parameters of the function table (F 1 to F 17)



3. Unpacking

Models
 HV-15KGL
 HV-15KGV
 HW-10KGL
 HW-10KGV

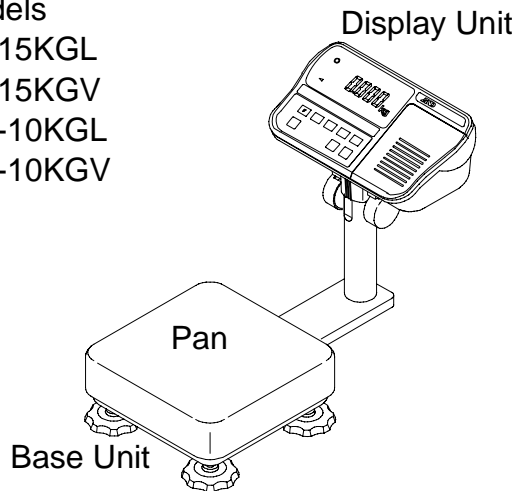

Models
 HV-60KGL HV-60KGV
 HW-60KGL HW-60KGV

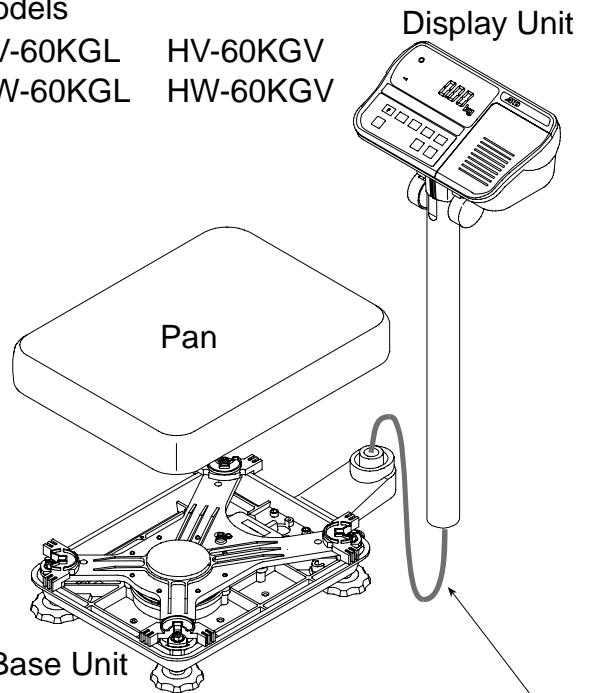

Caution
 Do not pull the load cell cable.

Models
 HV-200KGL HV-200KGV
 HW-100KGL HW-100KGV
 HW-200KGL HW-200KGV

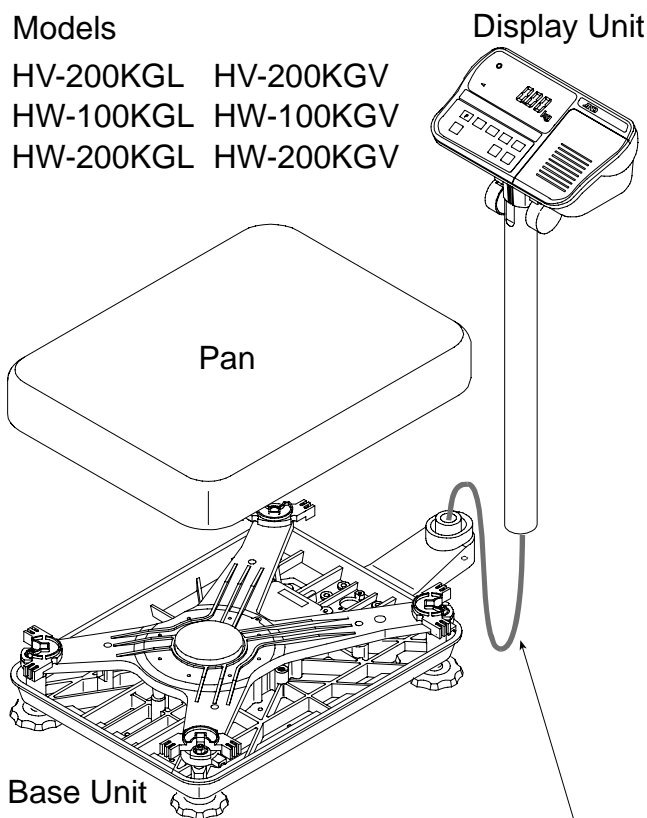

Caution
 Do not pull the load cell cable.

Accessories

Refer to "Accessories List" on page 7.
 Accessories supplied depend on the scale model.

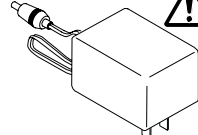
 **AC adapter**
 Please confirm that the AC adapter type is correct for your local voltage and receptacle type.

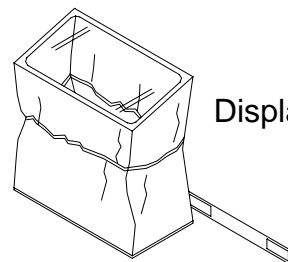
 **Display unit cover**

 **Allen wrench**

Models
 HW-300KGL4
 HW-300KGV4
 HW-600KGL4
 HW-600KGV4

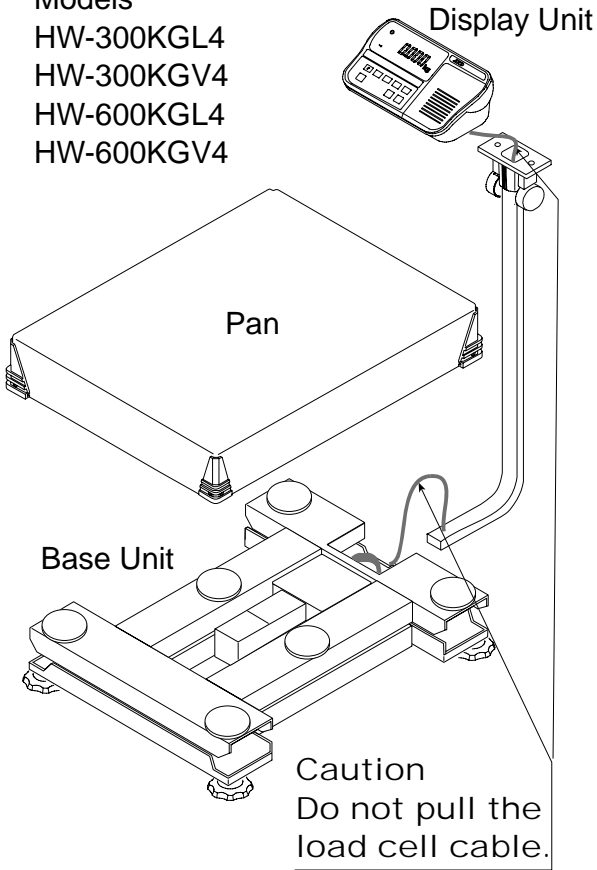

Models
 HW-600KGL3
 HW-600KGV3
 HW-1200KGL3
 HW-1200KGV3

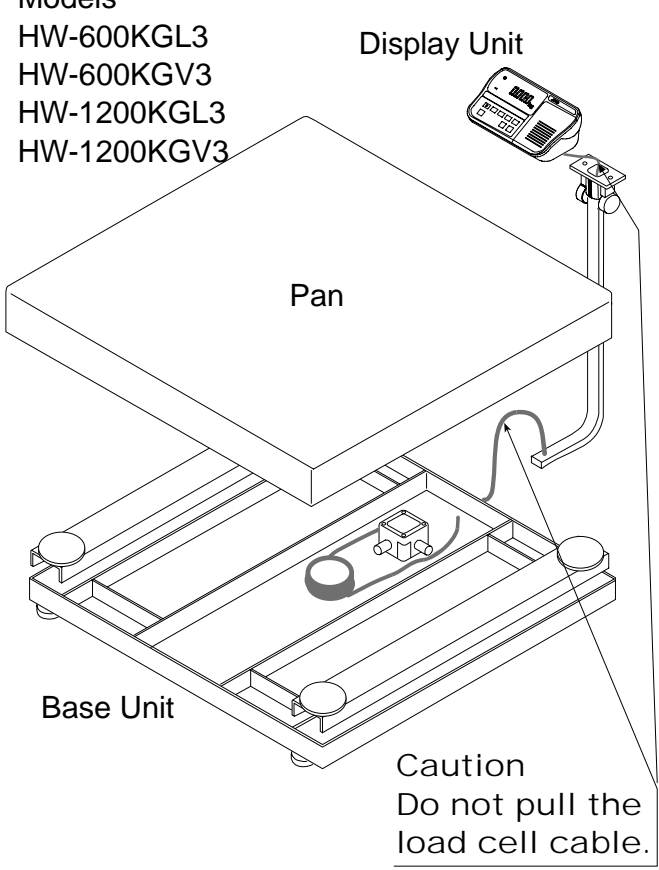

Accessories

Refer to "Accessories List" on the next page. Accessories supplied depend on the scale model.

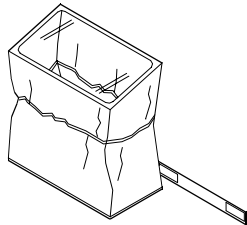

Display unit cover

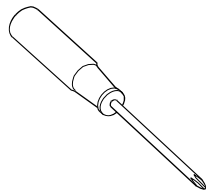

Phillips screwdriver

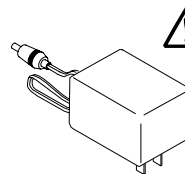

⚠ AC adapter
 Please confirm that the AC adapter type is correct for your local voltage and receptacle type.

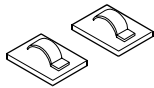

Cable clamp (2 pcs)

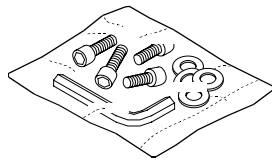

Set of Allen screws for pole installation (with Allen wrench)

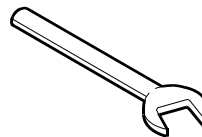

Wrench for leveling foot adjustment
 [HW-600KGL3/600KGV3
 1200KGL3/1200KGV3]

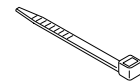

Cable tie (1 pc)



4 mm screw for display unit installation (2 pcs)



5 mm screw for pan installation (4 pcs) [HW-300KGL4/300KGV4
 600KGL4/600KGV4]

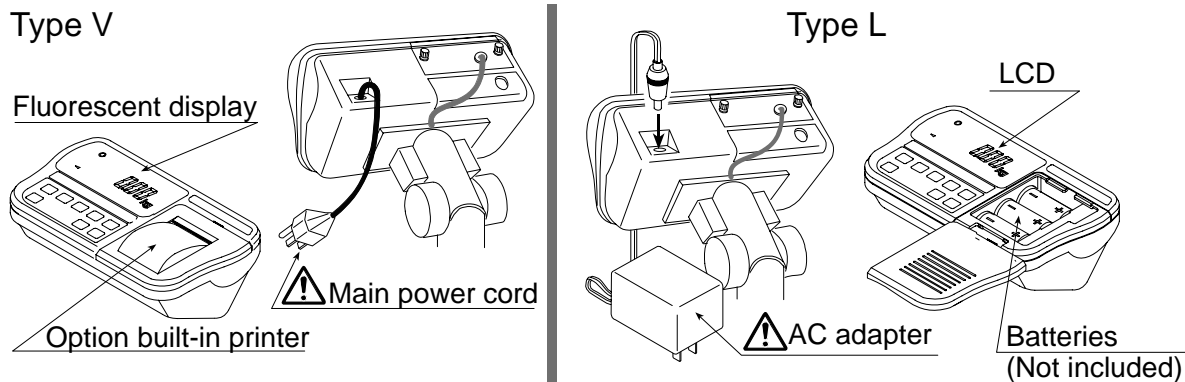

Please confirm that the main power type or AC adapter type is correct for your local voltage and receptacle type.

3.1. Accessories and Options List

Accessories List

Type	Models	Accessories (Quantity)	
V	HV-15KGV HW-10KGV	Display unit cover (1) Instruction manual (1)	
	HV-60KGV HV-200KGV HW-60KGV HW-100KGV HW-200KGV	Display unit cover (1) Allen wrench (1) Instruction manual (1)	
	HW-300KGV4 HW-600KGV4	Display unit cover (1) Phillips screwdriver (1) Cable clamp (2) Instruction manual (1)	5 mm screw for pan installation (4)
	HW-600KGV3 HW-1200KGV3	Set of Allen screws for pole installation with Allen wrench (1) Cable tie (1) 4 mm screw for display unit installation (2)	Wrench for leveling foot adjustment (1)
L	HV-15KGL HW-10KGL	Display unit cover (1) AC Adapter (1) Instruction manual (1)	
	HV-60KGL HV-200KGL HW-60KGL HW-100KGL HW-200KGL	Display unit cover (1) Allen wrench (1) AC Adapter (1) Instruction manual (1)	
	HW-300KGL4 HW-600KGL4	Display unit cover (1) Phillips screwdriver (1) AC Adapter (1) Cable clamp (2)	5 mm screw for pan installation (4)
	HW-600KGL3 HW-1200KGL3	Instruction manual (1) Set of Allen screws for pole installation with Allen wrench (1) Cable tie (1) 4 mm screw for display unit installation (2)	Wrench for leveling foot adjustment (1)

Note The AC adapter may not be provided for some areas.

Options List

Order code / Option name		Accessories
OP-02	Extension load cell cable (For weighing capacity of 10 kg to 200 kg) Extension load cell cable (For weighing capacity of 300 kg to 1200 kg)	Tapping screw M4x10
OP-03	RS-232C interface/ Relay output/ Buzzer	Connector JA:TCP0586
OP-04	RS-422/485 interface/ Relay output	Connector TM:BLA9 AC adapter
OP-06	Built-in printer for type V	Paper PP156 Ink ribbon ERC-05
OP-11	Wall mounting kit	
OP-13	Roller conveyor for HV-200KG, HW-100KG and HW-200KG	
OP-14	Roller conveyor for HV-60KG and HW-60KG	
OP-15	Display unit stand (The display is not included) For HW-300KGL4, HW-300KGV4, HW-600KGL4 and HW-600KGV4 For HW-600KGL3, HW-600KGV3, HW-1200KGL3 and HW-1200KGV3	
OP-16-3	Wheel for HW-600KGL3, HW-600KGV3, HW-1200KGL3 and HW-1200KGV3	
OP-16-4	Wheel for HW-300KGL4, HW-300KGV4, HW-600KGL4 and HW-600KGV4	
OP-17	Stainless steel cover for HW-600KGL3, HW-600KGV3, HW-1200KGL3 and HW-1200KGV3	
OP-18-3	Roller conveyor for HW-600KGL3, HW-600KGV3, HW-1200KGL3 and HW-1200KGV3	
OP-18-4	Roller conveyor for HW-300KGL4, HW-300KGV4, HW-600KGL4 and HW-600KGV4	
AX-KO577A-200	RS-232C cable, D-sub 25 pin, 2 m	
AX-KO1786-200	RS-232C cable, D-sub 9 pin, 2 m	

AX-KO577A-200

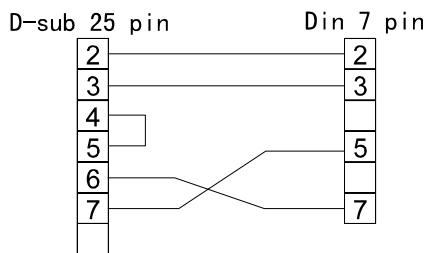

AX-KO1786-200

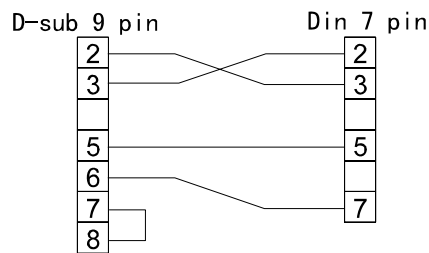

Note OP-16 and OP-17 are factory-installed.
For handling OPs-11, 13, 14, 15, 16, 17 and 18, refer to the relevant option manual.

Consumables

AX-PP156-S	Special roll paper (10 rolls)
AX-ERC-05-S	Ink ribbon (5 ink ribbons)



4. Precautions



4.1. Installing the Scale

Consider the following conditions to get the most from your scale.

- Install the scale where the temperature and relative humidity is stable, there is no draft and a stable power source is available.
- Install the scale on a solid and level surface.
- Do not install the scale in direct sunlight.
- Do not install the scale near heaters or air conditioners.
- ⚠ □ Do not install the scale where there is flammable or corrosive gas present.
- Do not install the scale near equipment which produces magnetic fields.
- Do not install the scale where there is apt to be static electricity, in a place where the relative humidity is lower than 45% RH. Plastic and isolators are apt to be charged with static electricity.
- The display unit is not water resistant. Use the display unit cover to avoid damage.
- Do not use an unstable power source.



4.2. Operating the Scale

- Periodically ensure that the weight value is correct.
- Calibrate the scale before using and after moving it to another location.
- Do not place anything on the pan which exceeds the weighing capacity.
- Do not drop anything upon the pan.
- Do not use a sharp instrument such as a pencil to press the keys. Press the keys gently using your finger.
- Pressing the **ZERO** key before each weighing is recommended to prevent possible error.
- Replace the used batteries with six new ones when the **BATT** mark is displayed. Battery is of type D, Mono, R20P, R20PU or LR20.



4.3. Storing the Scale

- Do not disassemble the scale.
- Do not use solvents to clean the scale. Wipe it with a dry lint free cloth or a lint free cloth which is moistened with warm water and a mild detergent.
- The base unit can be cleaned with gentle running tap water. Do not scratch the base unit with a brush. Allow the unit to dry before using.
- Protect the display unit from dust and water.
- Remove the batteries from the display unit when the scale is not to be used for a long time. If you leave the batteries installed, they may leak and damage the scale.



5. Installing the Scale



5.1. Setting up the Scale

The setup procedure depends on the scale model. Refer to the table below.

Models	Refer to
HV-15KGL/HV-15KGV/HV-60KGL/HV-60KGV/HV-200KGL/HV-200KGV/HW-10KGL HW-10KGV/HW-60KGL/HW-60KGV/HW-100KGL/HW-100KGV/HW-200KGL/HW-200KGV	Procedure A
HW-300KGL4/HW-300KGV4/ HW-600KGL4/HW-600KGV4	Procedure B
HW-600KGL3/HW-600KGV3/ HW-1200KGL3/HW-1200KGV3	Procedure C

5.1.1. Procedure A

HV-15KGL/HV-15KGV/HV-60KGL/HV-60KGV/HV-200KGL/HV-200KGV/HW-10KGL
HW-10KGV/HW-60KGL/HW-60KGV/HW-100KGL/HW-100KGV/HW-200KGL/HW-200KGV

This procedure includes all of the steps for installing the scales described above. Therefore, there may be some unnecessary steps for some models.

- Step 1 Take the base unit and pole out, taking care not to pull on the load cell cable.
- Step 2 Place the pan on the base unit.
- Step 3 Attach the pole to the bracket of the base unit, while using care not to damage the load cell cable. Insert the remainder of the load cell cable into the pole. Affix the pole to the bracket using two Allen screws.
- Step 4 Select a place for installing the scale. Refer to "4.1. Installing the Scale" .
- Step 5 Adjust the level of the base unit using the bubble spirit level and the leveling feet.
- Step 6 Press the caps at the pole top from both sides and adjust the angle of the display unit.
- Step 7 Check the weighing accuracy. If the scale needs calibration, refer to "14. Calibration".

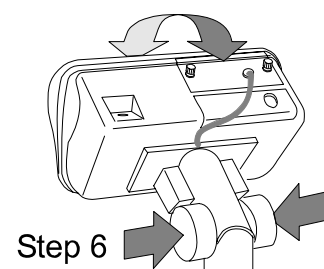
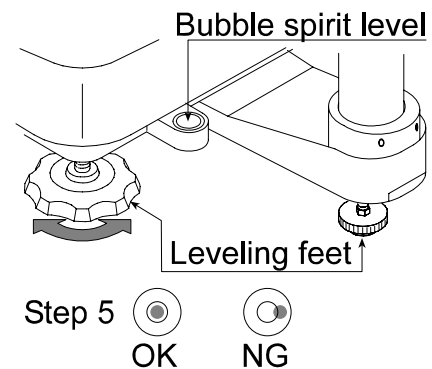
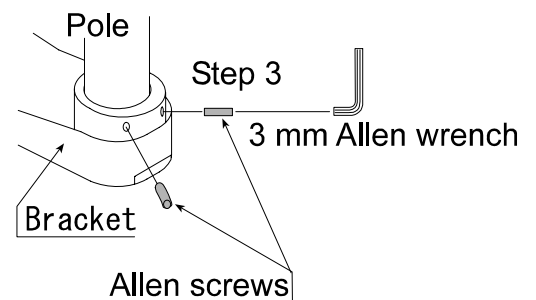
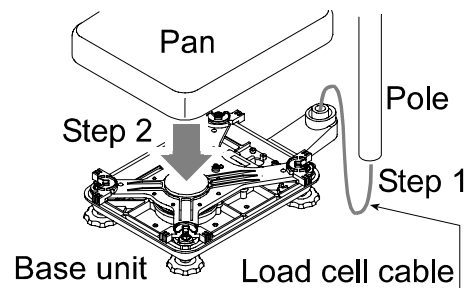

5.1.2. Procedure B

HW-300KGL4/HW-300KGV4
HW-600KGL4/HW-600KGV4

Note The display unit, the pole and the base unit are connected using cables. So, use care when lifting the display unit.

Step 1 Take the base unit, pole and display unit out, taking care not to pull on the load cell cable.

Step 2 Remove the pan.

Step 3 Attach the pole to the display unit with two 4 mm screws.
Attach the cable clamps on the back of the pole to organize the cables.

Step 4 Attach the pole to the base unit with four Allen screws and plain washers, while using care not to damage the load cell cable.
Using the cable tie, collect and bundle the remainder of the load cell cable.
Replace the pan.

Step 5 Affix the pan using the 5 mm screws.

Step 6 Select a place for installing the scale.
Refer to "4.1. Installing the Scale" .

Step 7 Adjust the level of the base unit using the bubble spirit level and the leveling feet.

Step 8 Press the caps at the pole top from both sides and adjust the angle of the display unit.

Step 9 Check the weighing accuracy. If the scale needs calibration, refer to "14. Calibration".

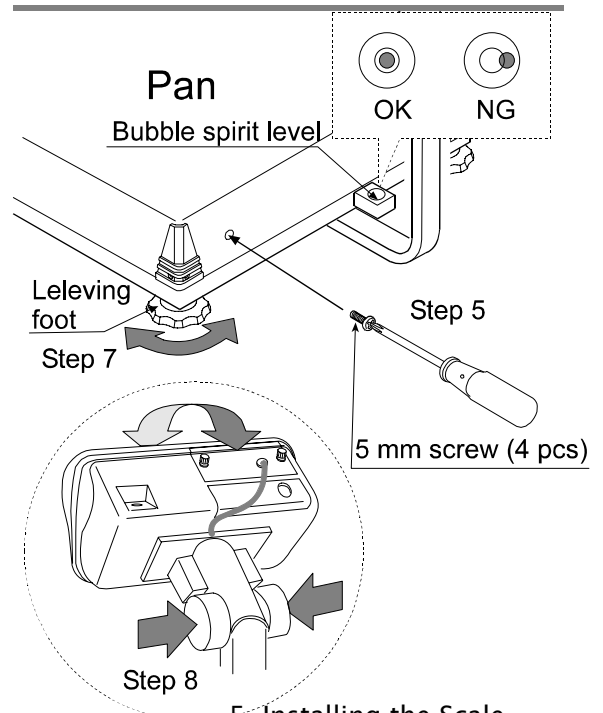
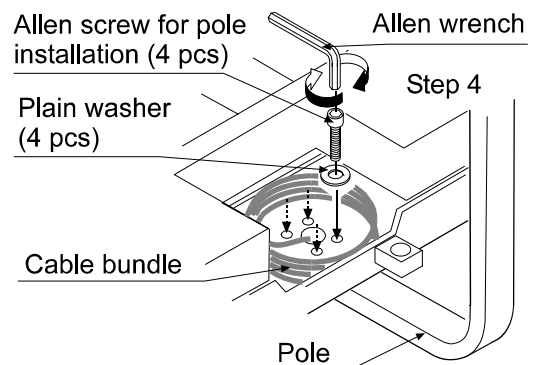
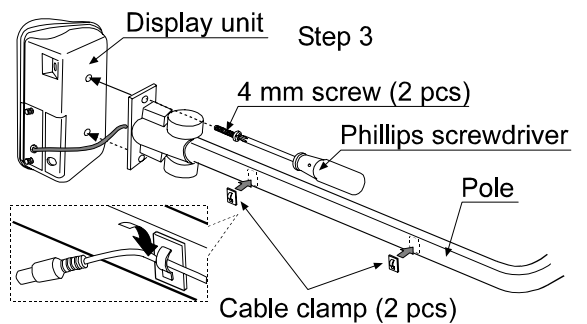
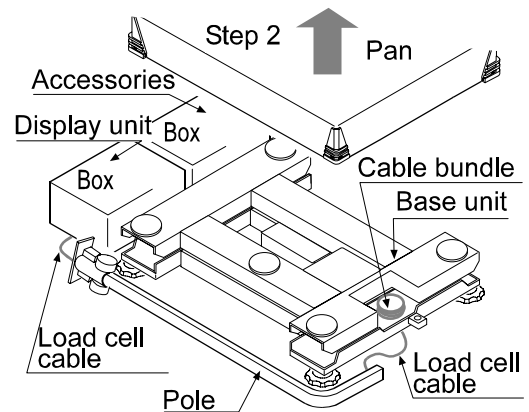

5.1.3. Procedure C

HW-600KGL3/HW-600KGV3
HW-1200KGL3/HW-1200KGV3

Note The display unit, the pole and the base unit are connected using cables. So, use care when lifting the display unit.

Step 1 Take the scale out.
The pole, the display unit and the accessories are found inside the base unit.

Step 2 Remove the pan and the accessories.

Step 3 Attach the pole to the display unit with two 4 mm screws.
Attach the cable clamps on the back of the pole to organize the cables.

Step 4 Attach the pole to the base unit with four Allen screws and plain washers, while using care not to damage the load cell cable.
Using the cable tie, collect and bundle the remainder of the load cell cable.

Step 5 Replace the pan in the direction as shown in the illustration.

Step 6 Select a place for installing the scale.
Refer to "4.1. Installing the Scale" .

Step 7 Adjust the level of the base unit using the leveling feet.

Note A bubble spirit level is not provided. (The load values on the four corners are added.)

Step 8 Press the caps at the pole top from both sides and adjust the angle of the display unit.

Step 9 Check the weighing accuracy. If the scale needs calibration, refer to "14. Calibration".

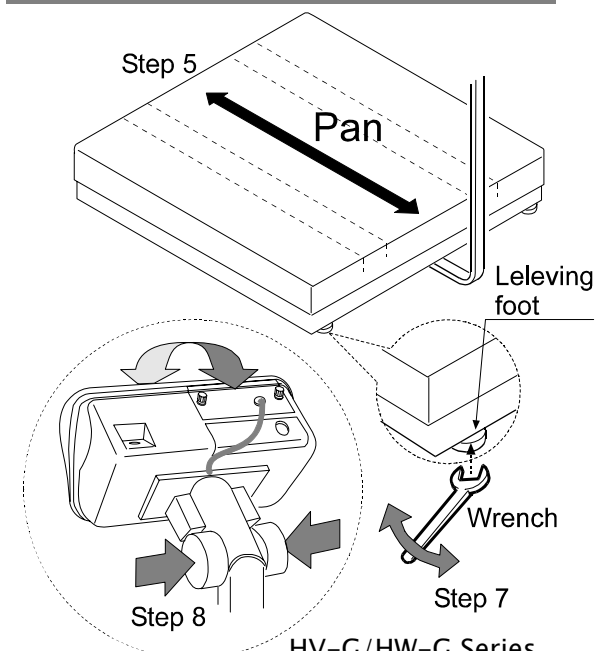
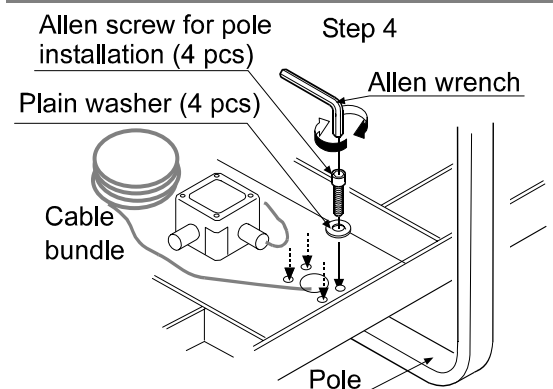
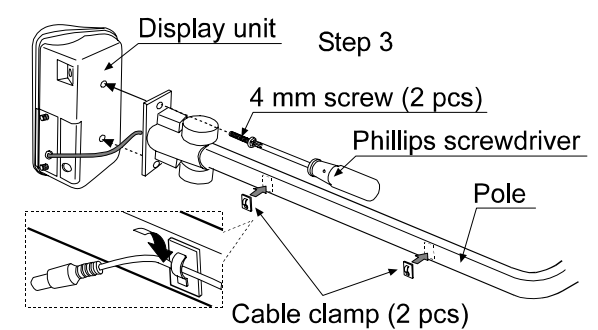
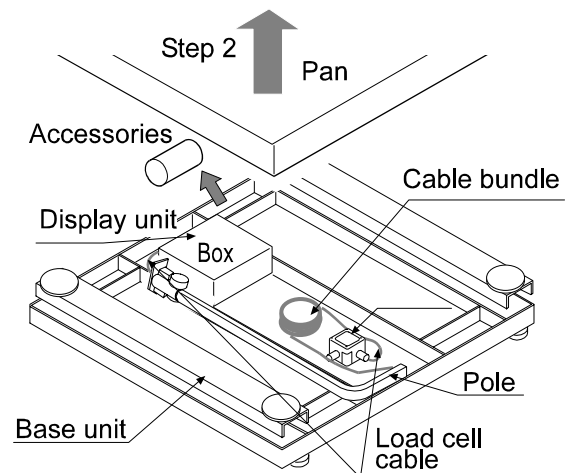



5.2. Installing the Batteries for Type L

- Step 1 Turn off the display.
Remove the AC adapter.

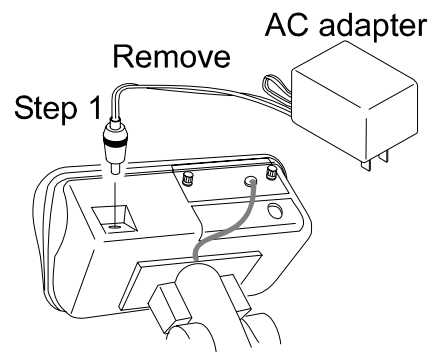

- Step 2 Press and slide the ext. cover to open it.
Press the hook of the int. cover to the left side and lift it.

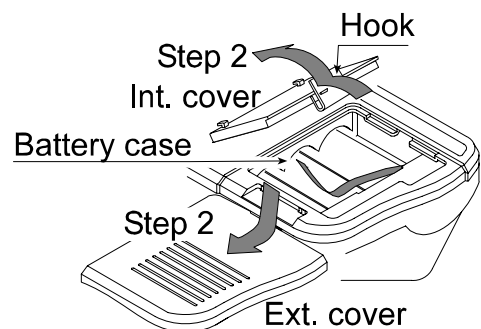

- Step 3 Insert six new batteries with proper polarity (+,-). Battery is of type D, Mono, R20P , R20PU or LR20.

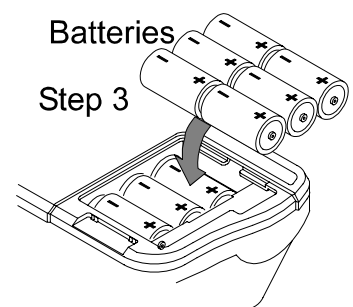

- Step 4 Close the covers in reverse order of step 2.

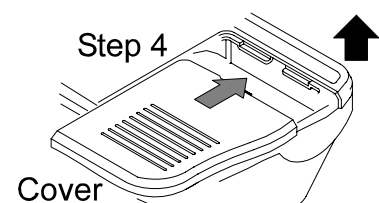

Caution

- ❑ Replace used batteries with six new ones, when **BATT** is displayed.
- ❑ Do not mix used and new batteries. It may cause damage to the batteries or the scale, if used.
Check the battery direction. If the batteries are installed in the wrong direction, it may cause battery leakage. If the direction of a single battery is wrong, the scale may work only temporarily.
- ❑ The battery life depends on the ambient temperature.
- ❑ Remove the batteries from the display unit, when the scale is not to be used for a long time. They may leak and cause damage.
- ❑ Damage which is due to battery leakage is not covered under warranty.



5.3. Removing the Pole

Caution

- ⚠ □ Remove the AC plug from the receptacle before removing the pole (type V). Remove the AC adapter and batteries before removing the pole (type L).
- When removing the load cell cable, do not pull on the load cell cable connector forcibly and do not pull on the wires of the cable.
- Do not bend the cable forcibly. Use care so that the load cell cable does not touch the pan inside the base unit.
- Avoid dust, static electricity and high humidity (or condensation) because the inside of the display unit is sensitive.

The pole removing procedure depends on the scale model. Refer to the table below.

Models	Refer to
HV-15KGL/HV-15KGV/HV-60KGL/HV-60KGV/HV-200KGL/HV-200KGV/HW-10KGL HW-10KGV/HW-60KGL/HW-60KGV/HW-100KGL/HW-100KGV/HW-200KGL/HW-200KGV	Procedure A
HW-300KGL4/HW-300KGV4/HW-600KGL4/HW-600KGV4/HW-600KGL3/HW-600KGV3 HW-1200KGL3/HW-1200KGV3	Procedure B

5.3.1. Procedure A

- Step 1** Turn the scale off.
Remove the AC plug from the receptacle (type V).
Remove the AC adapter and batteries (type L).
- Step 2** Open the rear cover of the display unit.
Disconnect the load cell cable connector gently (perpendicularly and do not pull toward you).
- Step 3** Remove the two 4 mm screws, which are used to attach the display unit to the pole.
- Step 4** Remove the ferrite core and the cable clamp from the load cell cable.
- Step 5**
(HV-60KGL/HV-60KGV/HW-60KGL/HW-60KGV/HV-200KGL/HV-200KGV//HW-100KGL/HW-100KGV
HW-200KGL/HW-200KGV only)
Remove the 3 mm screws from the bottom cover of the bracket.
- Step 6** Carefully remove the load cell cable from the pole and the bracket while using care not to pull on the connector forcibly.
- Step 7** Arrange the cable so that it does not touch the pan in the base unit. The untied cable is approximately 2 m. The optional extension load cell cable (OP-02) is 5 m long.
- Step 8** Remove the bracket from the base unit. An Allen wrench is required.

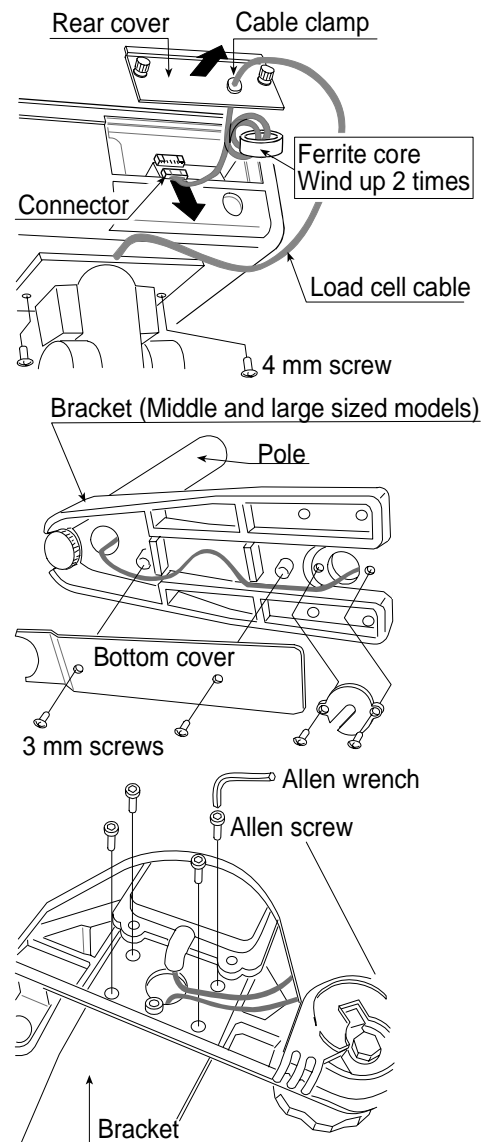

HV-15KGL/HV-15KGV HV-60KGL/HV-60KGV HW-10KGL/HW-10KGV HW-60KGL/HW-60KGV	HV-200KGL/HV-200KGV HW-100KGL/HW-100KGV HW-200KGL/HW-200KGV
5 mm Allen wrench	6 mm Allen wrench

Step 9 Wind the cable through the ferrite core two times. Affix the cable to the rear cover using the cable clamp.

Step 10 Connect the cable to the connector. Close the rear cover.

Step 11 Check the weighing accuracy.

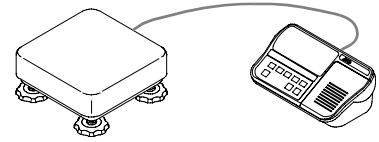

5.3.2. Procedure B

Step 1 Turn the scale off.
Remove the AC plug from the receptacle (type V).
Remove the AC adapter and batteries (type L).

Step 2 Open the rear cover of the display unit.
Disconnect the load cell cable connector gently (perpendicularly and do not pull toward you).

Step 3 Remove the two 4 mm screws, which are used to attach the display unit to the pole.

Step 4 Remove the ferrite core and the cable clamp from the load cell cable.

Step 5 Carefully remove the load cell cable from the pole using care not to pull on the connector forcibly.

Step 6 Arrange the cable so that it does not touch the pan in the base unit. The untied cable is approximately 4.5 m. The optional extension load cell cable (OP-02) is 5 m long.

Step 7 Remove the Allen screws, which are used to attach the pole to the base unit, and remove the pole.

Step 8 Wind the cable through the ferrite core two times. Affix the cable to the rear cover using the cable clamp.

Step 9 Connect the cable to the connector. Close the rear cover.

Step 10 Check the weighing accuracy.

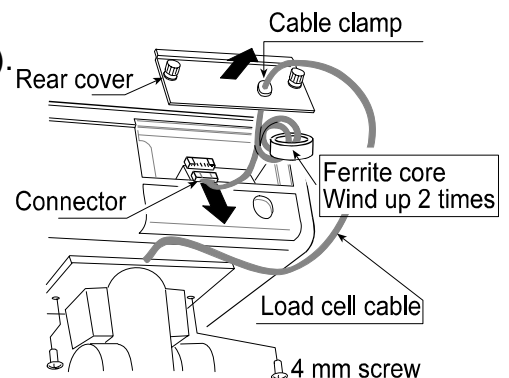

The shape of the base unit varies depending on the model as below.

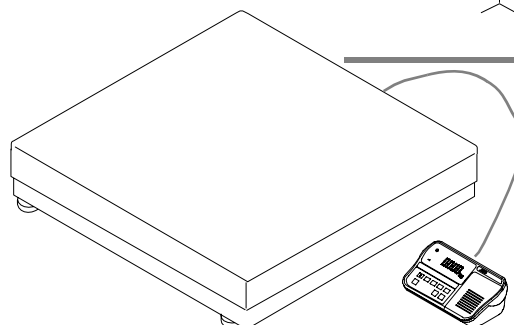
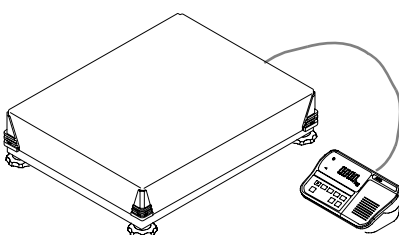
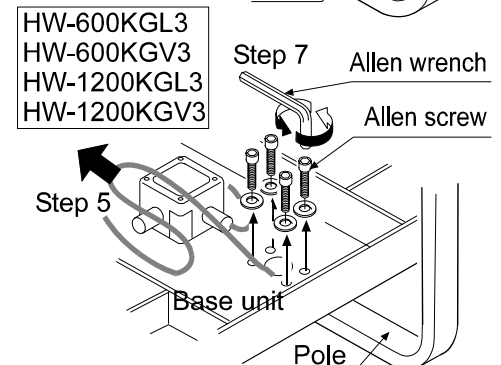
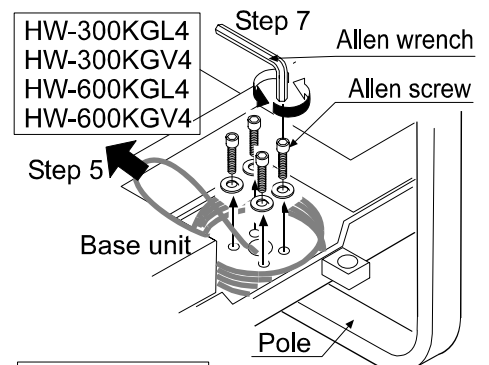



5.4. Grounding the scale

When using where there may be static electricity, ground the scale.

The grounding procedure depends on the scale model. Refer to the table below.

These procedures are only for grounding part of the scale.

Models	Refer to
HV-15KGL/HV-15KGV/ HW-10KGL/HW-10KGV	Procedure A
HV-60KGL/HV-60KGV/HV-200KGL/HV-200KGV/HW-60KGL/HW-60KGV HW-100KGL/HW-100KGV/HW-200KGL/HW-200KGV	Procedure B
HW-300KGL4/HW-300KGV4/ HW-600KGL4/HW-600KGV4	Procedure C
HW-600KGL3/HW-600KGV3/ HW-1200KGL3/HW-1200KGV3	Procedure D

Procedure A

(HV-15KGL/HV-15KGV/ HW-10KGL/HW-10KGV)

Secure the grounding cable using a M4 screw in the screw hole between the two hexagon bolts on the base unit bottom side. (Part of “⇨”)

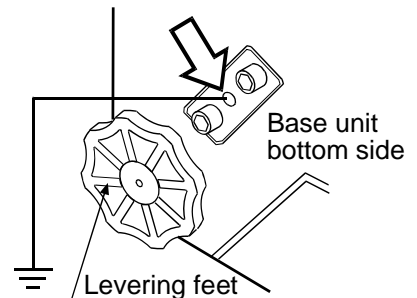

Procedure B

(HV-60KGL/HV-60KGV/HV-200KGL/HV-200KGV/HW-60KGL/
HW-60KGV/HW-100KGL/HW-100KGV/HW-200KGL/HW-200KGV)

Secure the grounding cable using the screw that secures the under cover. (Part of “⇨”)

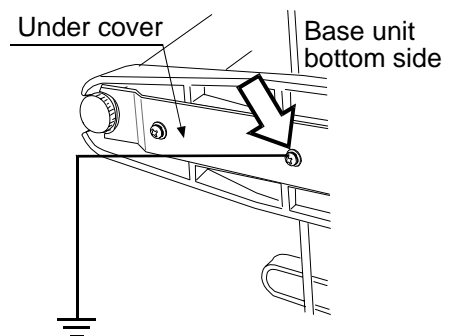

Procedure C

(HW-300KGL4/HW-300KGV4/ HW-600KGL4/HW-600KGV4)

Remove the pan. Secure the grounding cable using the screw that secures the band of the load cell cable bundle. (Part of “⇨”)

Pull the grounding cable through to the lower section through the channel. Be careful that the pan does not touch the grounding cable.

Pull the grounding cable through to the under side of the base.

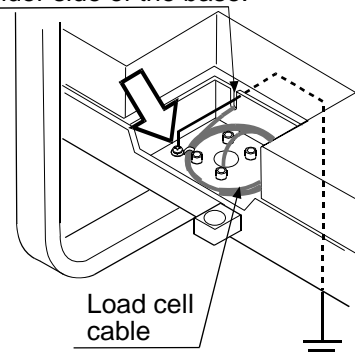

Procedure D

(HW-600KGL3/HW-600KGV3/HW-1200KGL3/HW-1200KGV3)

Remove the pan. Secure the grounding cable using the screw that secures the summing box. (Part of “⇨”)
Remove the cover located on the base's side. Pull the grounding cable out through this hole. Be careful that the pan does not touch the grounding cable.

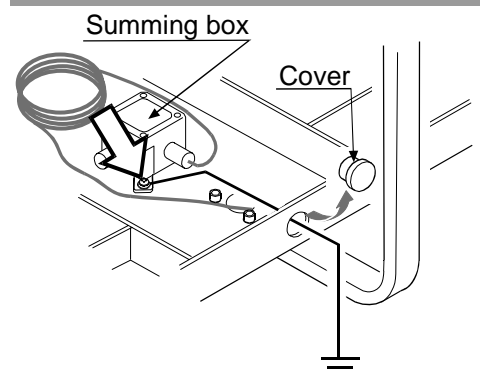



6. Description of Each Part

Models
 HV-15KGL
 HV-15KGV
 HW-10KGL
 HW-10KGV

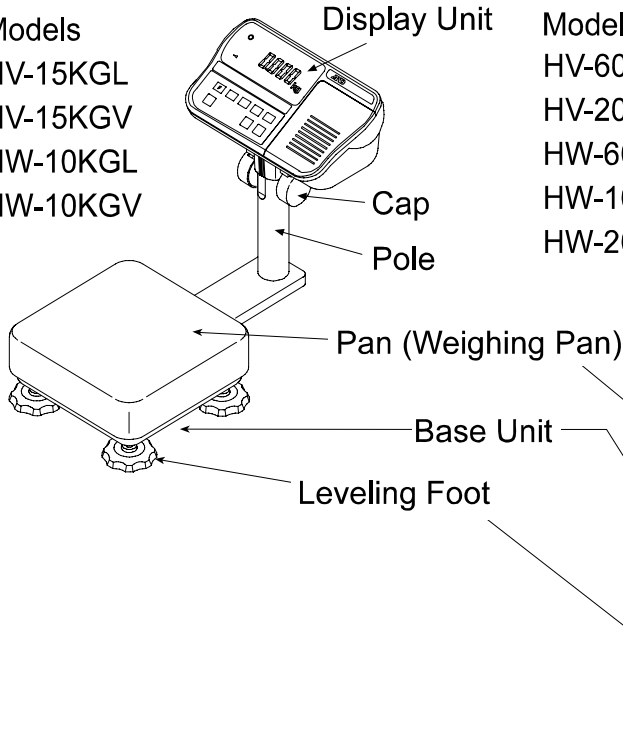

Models
 HV-60KGL HV-60KGV
 HV-200KGL HV-200KGV
 HW-60KGL HW-60KGV
 HW-100KGL HW-100KGV
 HW-200KGL HW-200KGV

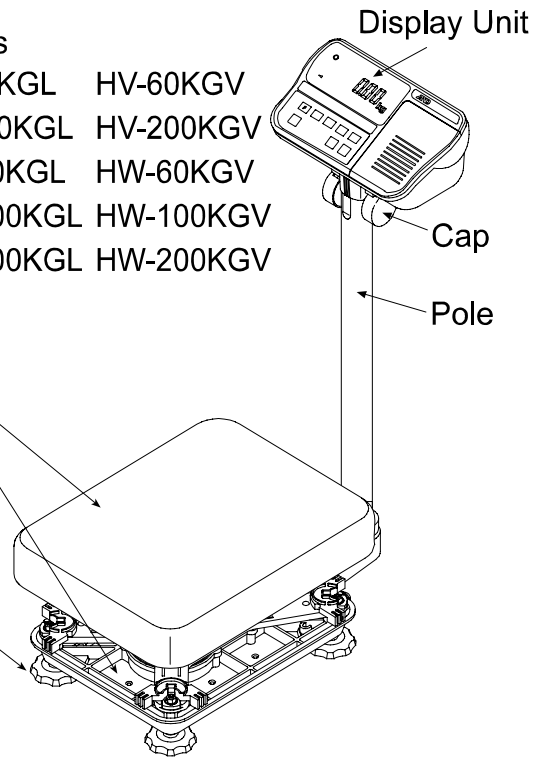

RS-232C Interface connector

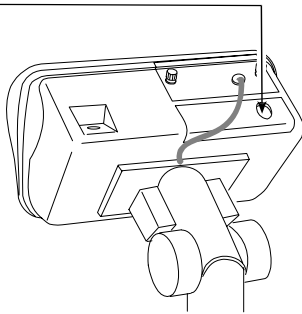

Type L

Battery Case

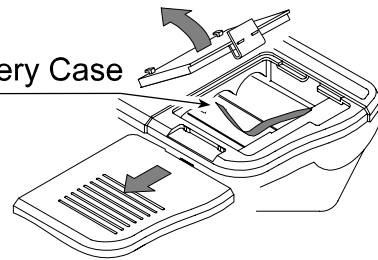

CAL switch
 Calibrating the scale
 to weigh correctly.

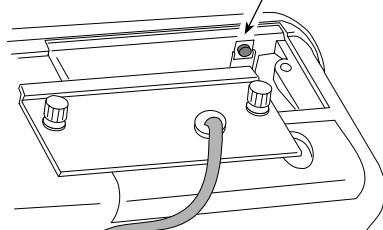

Caution
 The certified mass is required.

Leveling Foot

Bubble Spirit Level

Leveling Foot

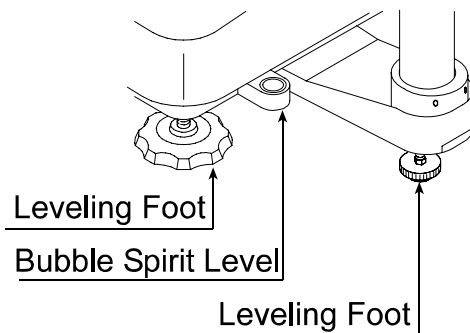

Models
 HW-300KGL4
 HW-300KGV4
 HW-600KGL4
 HW-600KGV4

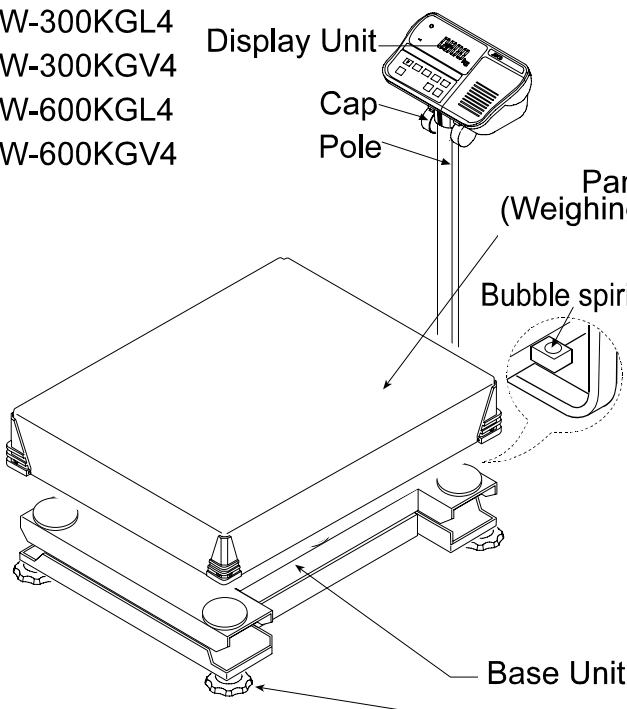

Models
 HW-600KGL3
 HW-600KGV3
 HW-1200KGL3
 HW-1200KGV3

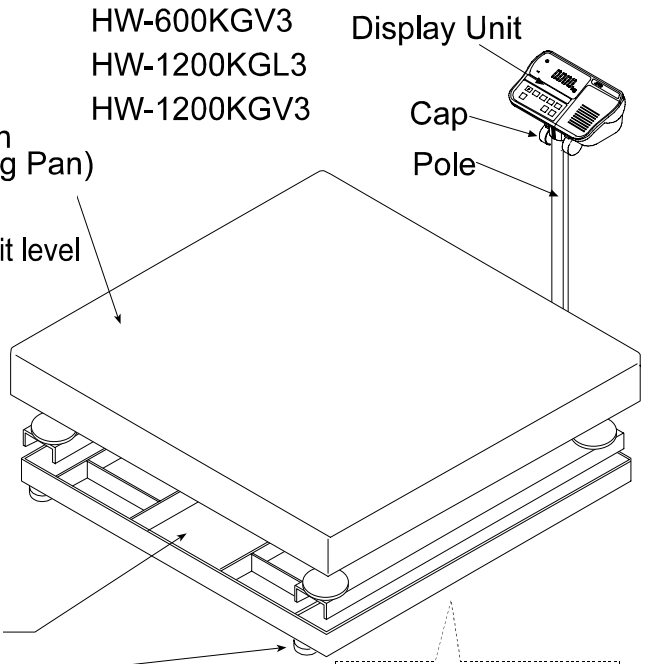

A bubble spirit level is not provided.

RS-232C Interface connector

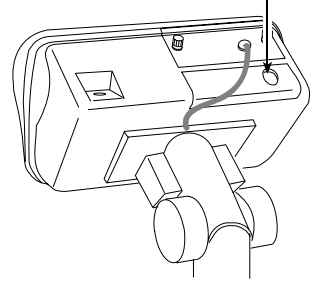

CAL switch
 Calibrating the scale to weigh correctly.

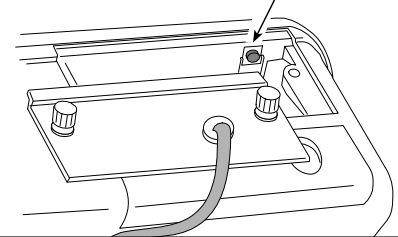

Caution
 The certified mass is required.





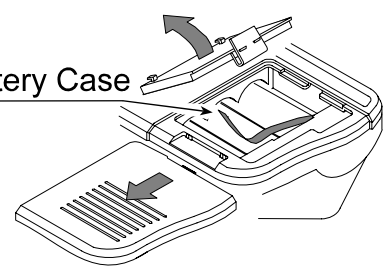

Type L

Battery Case



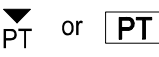
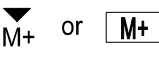

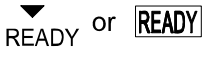
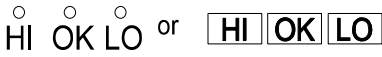



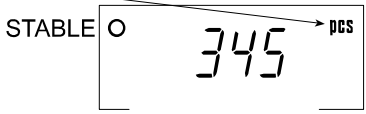
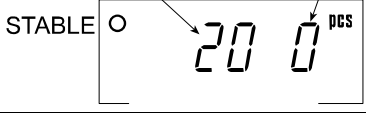
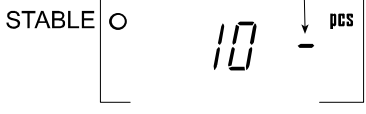
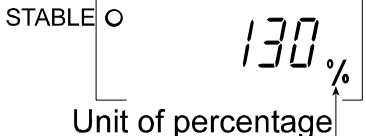
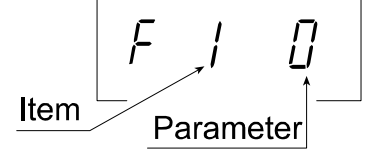
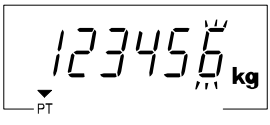
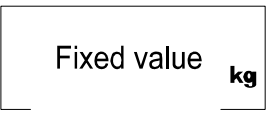
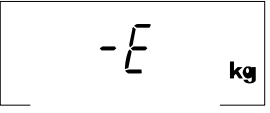
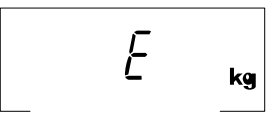
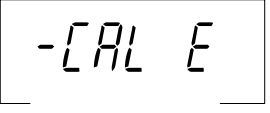



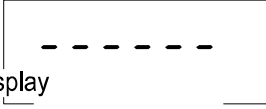

6.1. Display and Symbols



Display and Symbols	Description
	<p>Stability mark When the current weight value is stable, this mark is displayed. It means a proper condition that this value is readable.</p>
	<p>Zero point mark When the ZERO key is pressed with nothing on the pan, this mark is displayed. The zero point is the fundamental starting point to weigh anything.</p>
	<p>Net mark When the TARE key is pressed, this mark is displayed. Used to indicate that the mass of the container placed on the pan has been subtracted from the gross value.</p>
	<p>Preset tare mark While a tare with digital input is displayed, this mark blinks.</p>
	<p>Accumulation mark While the accumulation function is used, this mark is displayed.</p>
	<p>Low battery mark for type L When the battery is depleted (becoming low voltage), this mark is displayed. Replace with six new batteries.</p>
	<p>Ready mark for the full/dribble batch function. This mark means as follows:</p> <ul style="list-style-type: none"> ON The weight value is within the zero band. OFF The full/dribble batch process is above the zero band. Blinking The start or end of the full/dribble batch process is not within the zero band.
<p>e.g. HV-15KGV ▾ 15kg ▾ 6kg ▾ 3kg</p>	<p>Weighing range indicator for the HV-G series The current range is indicated.</p>
	<p>Comparator indicator</p> <ul style="list-style-type: none"> □ Using the comparator function: Indicates the result after a weight value is compared with the upper and lower limits. □ Using the full/dribble batch function: OK is the full flow gate indicator, HI is the dribble flow gate indicator and LO is the zero band gate indicator.
<p>Weighed mass value unit</p> 	<p>Zero point (Example) When the ZERO key is pressed with nothing on the pan, the zero point mark and the stability mark are displayed.</p>









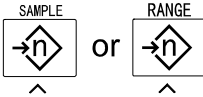

Display and Symbols	Description
<p>Unit of counting mode</p> 	<p>Counting mode (Example)</p> <p>This mode uses the stored unit mass and counts the number of articles on the pan. The unit is pcs.</p>
<p>20 pieces Zero value</p> 	<p>Storing the unit mass for the counting mode (Example)</p> <p>The unit mass is stored, using 20 pieces of samples. The zero value means that no articles are on the pan.</p>
<p>No zero value</p> 	<p>Storing the unit mass for the counting mode (Example)</p> <p>The unit mass is stored, using 10 pieces of samples. Sign "-" means that something is placed on the pan.</p>
<p>Unit of percentage</p> 	<p>Percentage mode (Example)</p> <p>This mode uses the stored 100% mass and converts the weight value to a percentage. The unit is %.</p>
<p>Item Parameter</p> 	<p>Function table (Example)</p> <p>This function table sets parameters of items.</p> <p>[ENTER] key Selecting an item.</p> <p>^ and < keys Selecting a parameter of the item.</p> <p>[ENTER] key Storing new parameters.</p>
	<p>Preset tare. Entering tare with digital input (Example)</p> <p>< key Selecting the figure to be changed.</p> <p>^ key Changing the number of the figure.</p> <p>[ENTER] key Storing the new tare.</p>
<p>Fixed value</p> 	<p>Hold display (Example)</p> <p>The hold display is set using F 12 of the function table. When the weight value is "nearly-zero" (within the zero band) or changes more than 25% +30 digits, the hold is canceled.</p>
	<p>Weighing error</p> <p>Check the base unit and the weighing pan.</p>
	<p>Overload display</p> <p>Remove anything that is on the pan.</p>
	<p>Calibration error</p> <p>The calibration mass is too light.</p> <p>Check the base unit and the weighing pan.</p>

The "digit" is a unit of display, and is equivalent to the minimum measurable mass.
The "nearly-zero" or zero band is within ± 5 digits from zero point in the unit of kg.

Display and Symbols	Description
	Calibration error The calibration mass is too heavy. Check the base unit and the weighing pan.
Fixed display 	Does not display zero when the scale is turned on. Remove anything that is on the weighing pan. Perform zero point calibration. Or The weight value is unstable due to drift or vibration when the scale is turned on. A breeze or vibration may be affecting the measurement. Check around the weighing pan.
Blinking  or 	Accumulated data count
Blinking  or 	Total mass value of the accumulated data
Blinking  or 	Comparator function: upper limit value Full/dribble batch function: final value
Blinking  or 	Full/dribble batch function: preliminary value
Blinking  or 	Comparator function: lower limit value Full/dribble batch function: zero band
e.g. CAP. MAX. 3/6/15kg d=1/2/5g	The weighing range and measurable minimum mass. Example: Displays the weight value by 5 g up to 15 kg. Displays the weight value by 2 g up to 6 kg. Displays the weight value by 1 g up to 3 kg.

6.2. Keys

Display and Symbols	Description
	ON/OFF key Note Type V is in standby status when power is connected.
	ZERO key When the ZERO key is pressed with nothing on the pan, the scale displays the mass value of zero and the zero point mark. Net is canceled, if it is displayed.
	TARE key Canceling the mass of a container which is placed on the pan and does not weigh its mass.
	SAMPLE key, RANGE key, ^ key <ul style="list-style-type: none"> □ Changes the weighing range for HV-G series.(Refer to F2) □ Storing the unit mass: used to select the number of samples.

	Function table: used to select a parameter.
Display and Symbols	Description
	<p>SET key, < key</p> <ul style="list-style-type: none"> □ Normal weighing mode: used to turn the comparator on or off. (Refer to <i>F 5</i>) □ Counting mode: used to enter the mode to store the unit mass. □ Percentage mode: used to enter the mode to store the 100% mass. □ Full/dribble batch function: used as a start key. □ Preset tare and calibration mass selection: used to select a figure.
	<p>MODE key, ENTER key</p> <ul style="list-style-type: none"> □ Used to change the current unit. □ Setting mode: used to store a parameter and proceed to the next step.
	<p>F key</p> <ul style="list-style-type: none"> □ Full/dribble batch function: used to finish the process. (Refer to <i>F 10</i>) □ Hold key. (Refer to <i>F 12</i>) □ Comparator function: used to select the polarity (+,-).
	<p>PRINT key</p> <ul style="list-style-type: none"> □ Used to print or output data. (Refer to <i>F 5, F 9</i>)
<p>Display off ↓ Press and hold  And press </p>	<p>Used to enter the function table.</p>
<p>Press and hold  And press </p>	<p>Used to enter the mode to set a preset tare.</p>
<p>Press and hold  And press </p>	<p>Used to feed the paper to the optional printer for type V.</p>

7. Basic Operation

7.1. Turning the Scale on/off and Weighing

7.1.1. Type V or Type L with AC Adapter

- Step 1 Ground the scale.
- Step 2 Confirm that nothing is placed on the pan.
- Step 3 Confirm that local voltage and receptacle type are correct.
- Step 4 The scale turns on/off using the **ON/OFF** key alternately.
- Step 5 Check the accuracy of weighing. Allow 30-minute warm up before calibration.
- Step 6 With nothing on the pan, press the **ZERO** key to display zero.
- Step 7 Place an article to be weighed on the pan gently.
- Step 8 Wait for the stability mark to be displayed. Read the weight value.
- Step 9 Remove the article from the pan.
- Step 10 Turn the scale off using the **ON/OFF** key.

Memo

- With the power cord connected, type V is in standby status after the scale is turned off using the **ON/OFF** key. To shut down the power completely, disconnect the power cord.
- With the AC adapter connected, the power is off at the scale, but not from the AC adapter, after the scale is turned off using the **ON/OFF** key. To shut down the power completely, disconnect the AC adapter.

7.1.2. Type L with Batteries

Step 1 Install six new batteries. Refer to "5.2. Installing the Batteries for Type L".

Step 2 Confirm that nothing is placed on the pan.

Step 3 The scale turns on/off using the **ON/OFF** key alternately.

Step 4 Check the accuracy of weighing. Allow 30-minute warm up before calibration.

Step 5 With nothing on the pan, press the **ZERO** key to display zero.

Step 6 Place an article to be weighed on the pan gently.

Step 7 Wait for the stability mark to be displayed. Read the weight value.

Step 8 Remove the article from the pan.

Step 9 Turn the scale off using the **ON/OFF** key.

Caution

- **Replace used batteries with six new ones when **BATT** is displayed.**
- **Battery life depends on the ambient temperature.**
- **Remove the batteries from the display unit when the scale is not to be used for a long time. The batteries may leak and cause damage.**



7.2. Tare (And Net Display)

The "tare" is used to cancel the mass of a container, which is placed on the pan to contain the article to be weighed.

Caution

- The tare reduces the weighing range.
- The current tare value is reset by pressing the **ZERO** key or turning the scale off. (Reset value is zero.)
- The storable preset tare value must be within the minimum weighing range for the HV-G series.

7.2.1. Tare Input by Weighing

Step 1 Place the container on the pan.

Step 2 Wait for the stability mark to be displayed. Press the **TARE** key. The display becomes zero and the net mark is displayed.

Step 3 Place an article to be weighed into the container. Wait for the stability mark to be displayed and read its net display.

Step 4 Remove the article and the container from the pan.

7.2.2. Digital Input (Preset Tare)

Step 1 Press and hold the **SET** key and press the **TARE** key.

Then the blank or stored tare value is displayed. The blank display means that the tare value is zero (reset value). And **PT** or **PT** blinks.

Step 2 Set the preset tare value using the following keys.

< key Selecting the figure to be changed.

^ key Changing the number of the figure.

Step 3 Press the **ENTER** key to store the new preset tare value.

Then the scale displays the net value (the gross weight value minus the tare value).

Step 4 Place an article to be weighed into the container. Wait for the stability mark to be displayed and read its net display.

Step 5 Remove the article and the container from the pan.



7.3. Weighing Range for the HV-G Series

- This is the function to select a weighing range for the HV-G series. The mass value is displayed within a selected range.
- Select automatic range (F2 0) or manual range (F2 1) in the function table.

Operation and Performance

Function table	Description
F2 0	<p>Automatic range</p> <ul style="list-style-type: none"> □ The weighing range changes automatically, if the weight value proceeds from narrow range to wide range when articles are placed on the pan. □ When there is nothing on the pan and the zero point mark is displayed, the weighing range changes to the minimum range automatically. □ When the zero point mark is not displayed due to net display or zero error, press the ZERO key, with nothing on the pan, to change to the minimum range.
F2 1	<p>Manual range</p> <ul style="list-style-type: none"> □ Press the RANGE key to expand the range. □ Press the RANGE key to change to the minimum range, when there is nothing on the pan and the zero point mark is displayed. □ When the zero point mark is not displayed due to net display or zero error, press the ZERO key and the RANGE key, with nothing on the pan, to change to the minimum range.

Weighing Range

Models	Weighing range
HV-15KGV, HV-15KGL	3 kg, 6 kg, 15 kg
HV-60KGV, HV-60KGL	15 kg, 30 kg, 60 kg
HV-200KGV, HV-200KGL	60 kg, 150 kg, 220 kg



7.4. Mode Key (Changing Unit and Mode)

Pressing the **MODE** key changes the display as follows. Refer to function table *F3* for units. Usable units are according to the factory settings.

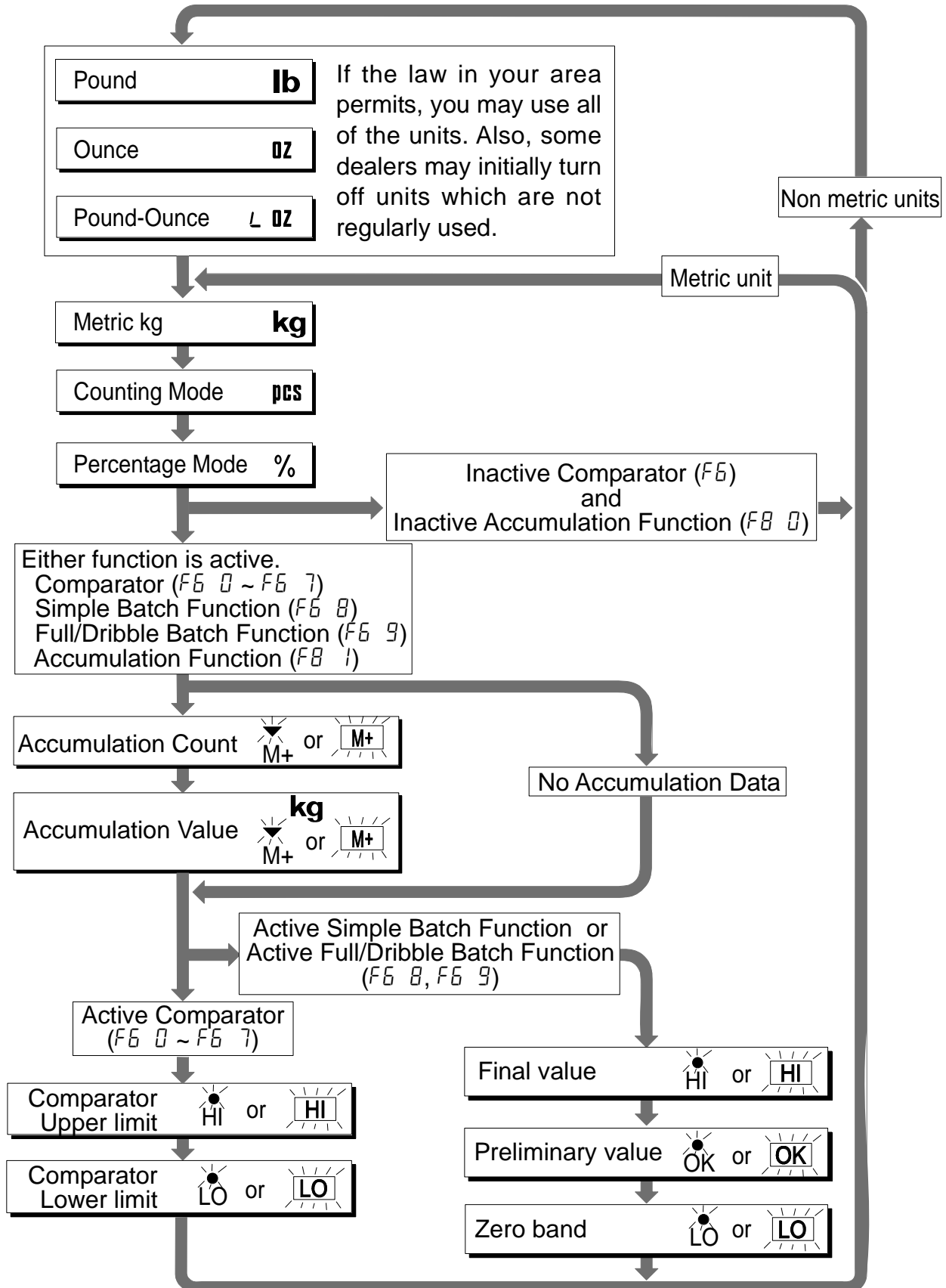

Description

- The status of "Inactive comparator (F6)" is that comparator function (F6 0, F6 2, F6 4, F6 6) is selected and this comparator is not used. The comparator can be selected to be ON or OFF using the **SET** key alternately.
- The following parameters are stored in the same memory. Therefore these functions can not be used at the same time. If you use each function, select the function in the function table, set the parameters (HI,OK and LO) and weigh.

	Indicator and Output		
	HI	OK	LO
Upper/Lower Comparator Function (F6 0 to 7)	Upper limit		Lower limit
Simple Batch Function (F6 8)	Final value	Preliminary value	Zero band
Full/ Dribble Batch Function (F6 9)	Final value	Preliminary value	Zero band

8. Counting Mode

- The counting mode is the function to convert the total mass value (total weight) of articles to a count, when each article has the same mass value.
- To use this function, store a unit mass in advance.
- Even if the AC adapter or the batteries is removed, the unit mass is maintained in non-volatile memory.

8.1. Storing a Unit Mass

Step 1 Press the **MODE** key to display the unit **pcs**.

Step 2 Press the **SET** key to enter the mode that stores a unit mass.

Step 3 Press the **△** key to select the number of samples.
The greater the quantity of samples, the greater the accuracy of the count.
5 pieces, 10 pieces, 20 pieces, 50 pieces,
100 pieces

Step 4 Place the container on the pan.
Press the **TARE** key.

Step 5 Place the number of samples selected at step 3.
Wait for the stability mark to be displayed. Press the **ENTER** key to store. The count is displayed.

Caution

- When the sample total mass value is too small and it is not possible to calculate a unit mass, the scale displays **Lo ut** and returns to step 3. Increase the number of samples. More than 5 digits of the total sample mass, in the unit of kg, are required.
- When the unit mass is too light to store, the scale displays **Lo ut**. In this case, the unit mass will not be stored even if the number of samples is increased.
- Pressing the **ENTER** key, after **Lo ut** is displayed, displays the next unit.

Step 6 Remove the samples and the container from the pan.

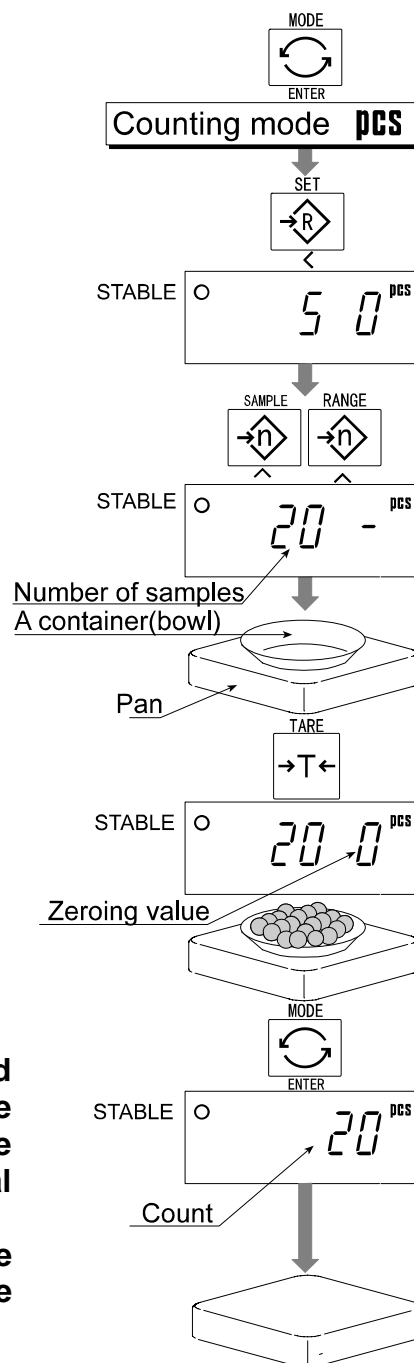

Note
The pan shape depends on the scale model.



8.2. Counting the Number of Articles

Step 1 Press the **MODE** key to display the unit **pcs**.

Step 2 Store the unit mass of the article.
Refer to "8.1. Storing a Unit Mass"

Step 3 Place the container on the pan.
Press the **TARE** key.

Step 4 Place articles in the container. Wait for the stability mark to be displayed and read the count.

Step 5 Remove the articles and the container from the pan.

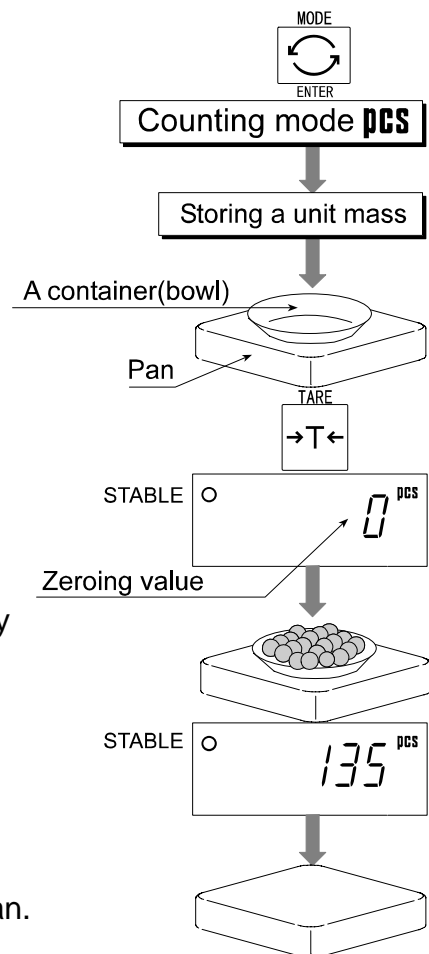

Note
The pan shape depends on the scale model.



9. Percentage Mode

- The percentage mode is the function to display a mass value in the unit of "%".
- To use this function , store a 100% mass value in advance.
- The 100% mass value is stored in the scale even if the power is removed.



9.1. Storing a 100% Mass

Step 1 Press the **MODE** key to display the unit %.

Step 2 Press the **SET** key to enter the mode that stores a 100% mass.

Step 3 With nothing on the pan, press the **ZERO** key to display zero.

Step 4 Place the 100% mass on the pan gently.
Wait for the stability mark to be displayed. Press the **ENTER** key to store. The percentage is displayed.

Caution

- **When the sample is too light and it is not possible to calculate a 100% mass, the scale displays **Lo** and returns to step 3.**
- **Pressing the **ENTER** key, after **Lo** is displayed, displays the next unit.**

Step 5 Remove the mass from the pan.

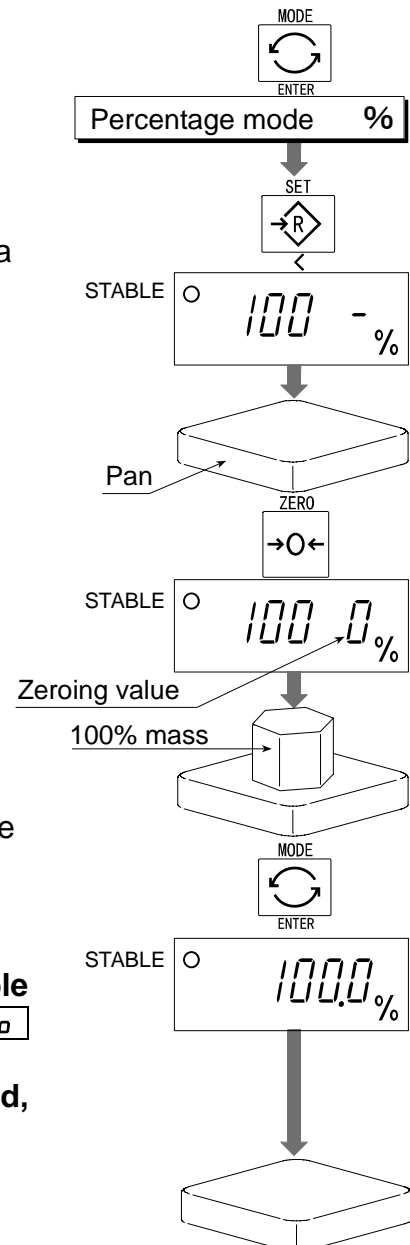

Note
The pan shape depends on the scale model.

9.2. Reading the Percentage

Step 1 Press the **MODE** key to display the unit %.

Step 2 Store the 100% mass of the article.
Refer to "9.1. Storing a 100% Mass "

Step 3 Place the container on the pan.
Press the **TARE** key.

Step 4 Place articles in the container. Wait for the stability mark to be displayed and read the percentage.

Step 5 Remove the articles and the container from the pan.

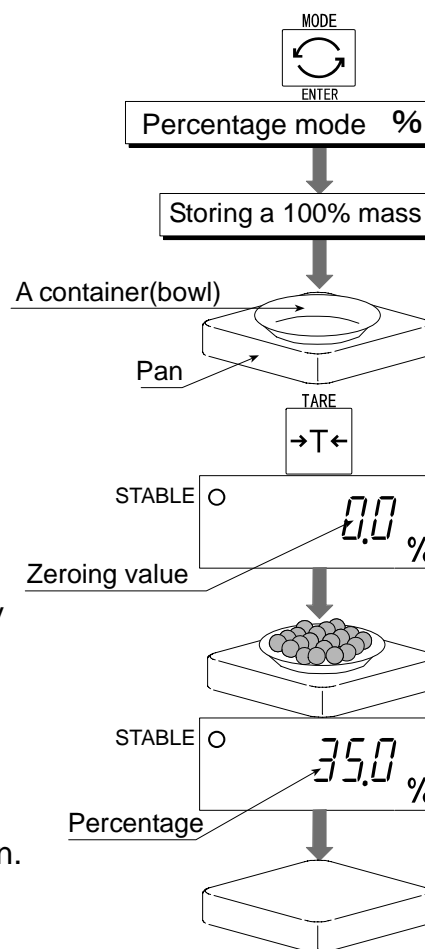

Note
The pan shape depends on the scale model.



10. Accumulation Function

- This function counts the number of times articles are weighed, calculates the total mass value and can display the number (accumulation count) and accumulated mass value.
- The accumulation function is displayed with up to 6 digits. The balance can not display 7 or more digits, therefore the leading digits are not displayed.
Example: With 60K type, when importing the data of 17 accumulations of up to 60kg (60.000 X 17=1020.000), the balance displays this as "020000".
- To use this function, set the parameters of the "Accumulation function (FB)" in the function table in advance.
- To use the built-in printer, set the parameters of the "Print mode (F9 5)" in the function table in advance.
- The accumulation count and accumulated mass value are stored in the scale even if the power is removed.

Operation and Keys

- The display of the accumulation count has a blinking M+ or M+ without a unit.
- The display of the accumulated mass value has a unit and a blinking M+ or M+.
- Press the MODE key to display the accumulation count and accumulated mass value.
- Press the ZERO key in the accumulation function (with a blinking M+ or M+) to reset the current function (The count and accumulated mass value become zero.)
- When the optional built-in printer is installed and the PRINT key is pressed, the accumulation data, date and data number are printed. Date is set at function table F17.

Caution

The accumulation function is available only when weighing is performed in the same unit.

Parameter List and Word Definition

- The "nearly-zero" is within ± 5 digits from the zero point in the unit of kg.
- The "digit" is a unit of display, and is equivalent to the minimum measurable mass.
- The "zero point" is the fundamental starting point to weigh anything.

Function table	Description
FB 0	Accumulation function not used.
FB 1	The scale accumulates the data, if the F key is pressed, when the display is a positive stable value and not nearly-zero. The next accumulation can be performed after the display becomes nearly-zero or a negative value.
FB 2	The scale accumulates the data, if the F key is pressed, when the display is a stable value and not nearly-zero. The next accumulation can be performed after the display becomes nearly-zero.

Function table	Description
FB 3	When the display is a positive stable value and not nearly-zero, the scale accumulates the data automatically. The next accumulation can be performed after the display becomes nearly-zero or a negative value.
FB 4	When the display is a stable value and not nearly-zero, the scale accumulates the data automatically. The next accumulation can be performed after the display becomes nearly-zero. Use Recording the number and mass of articles removed from the pan. (Place the articles on the pan. Press the TARE key at each removal.)
FB 5	At each end of the full/dribble batch function, the scale accumulates the data automatically. Use Packaging articles like a powder, it is used for recording the number of bags and the total mass.

10.1. Preparation (Setting Parameters)

Step 1 Turn off the display.

Press and hold the **ZERO** key and press the **ON/OFF** key. The function table is displayed.

Step 2 Press the **ENTER** key to display an item of the accumulation function (**FB**).

Step 3 Select a parameter of the accumulation function (**FB 1** to **FB 4**) with the **▲** key.



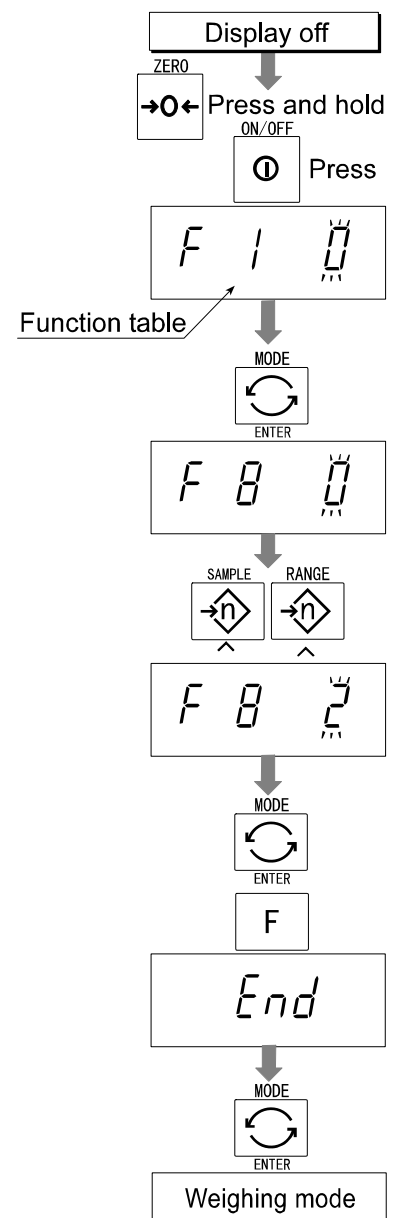

Step 4 Press the **ENTER** key and the **F** key to display **End**. Press the **ENTER** key to return to the normal weighing mode.



10.2. Operation and Performance (Examples)





Example 1

In this example, the scale accumulates the value each time an article is weighed. The function parameter is set to **FB 3**.

- Step 1 Press the **MODE** key to display  or .
- Step 2 Press the **ZERO** key to reset the accumulation data.
- Step 3 Return to the kg mode using the **MODE** key.
- Step 4 Place an article on the pan. Wait for the stability mark to be displayed and the value to be blinking. Remove the article and press the **ZERO** key.
- Step 5 Weigh additional articles using step 4.
- Step 6 Press the **MODE** key to display the accumulation count and accumulated mass value with  or .

Example 2

In this example, the scale accumulates the articles that are removed from the pan. The function parameter is set to **FB 4**.

- Step 1 Enter the kg mode using the **MODE** key.
Place all articles on the pan and press the **TARE** key.
- Step 2 Press the **MODE** key to display  or .
- Step 3 Press the **ZERO** key to reset the accumulation data.
Return to the kg mode using the **MODE** key.
- Step 4 Remove an article from the pan. Wait for the stability mark to be displayed and the value to be blinking. Press the **TARE** key.
- Step 5 Weigh additional articles using step 4.
- Step 6 Press the **MODE** key to display the accumulation count and accumulated mass value with  or .



11. Upper/Lower Comparator Function

- This function compares a weight value with the upper limit (HI) and the lower limit (LO) and displays the results.
- To use this function, set the "Comparator function ([F6 0] to [F6 7])" parameters in the function table, upper limit value (HI) and lower limit value (LO).
- Install option OP-03 or OP-04 to use relay output of the comparator.
- Install option OP-03 to use buzzer output of the comparator.
- The settings are stored in the scale even if the power is removed. (Refer to Caution on the next page.)

Comparator Indicators

Comparison results are displayed by indicators $\overset{\circ}{\text{HI}}$ $\overset{\circ}{\text{OK}}$ $\overset{\circ}{\text{LO}}$ or **HI** **OK** **LO**

Comparison Condition

Weight value < Lower limit valueLO is displayed and output.

Lower limit value \leq Weight value \leq Upper limit value.....OK is displayed and output.

Upper limit value < Weight valueHI is displayed and output.

Parameter List and Word Definition

- The decimal point is not displayed in the upper or lower limit value settings.
- The "nearly-zero" is within ± 5 digits from the zero point in the unit of kg.

Function table	Description
F6 0	Press the SET key to compare the current weight value always. Press the SET key again to stop the comparison.
F6 1	The scale always compares the weight value.
F6 2	Press the SET key to always compare the weight value when not nearly-zero. Press the SET key again to stop the comparison.
F6 3	The scale always compares the weight value when not nearly-zero.
F6 4	When the weight value becomes stable after the SET key is pressed, the scale compares the weight value. It does not compare on an unstable condition. Press the SET key again to stop the comparison.
F6 5	When the weight value is stable, the scale compares the weight value. It does not compare on an unstable condition.
F6 6	When the weight value becomes stable and not nearly-zero after pressing the SET key, the scale compares the weight value. It does not compare on an unstable condition. Press the SET key again to stop the comparison.

Function table	Description
F6 7	When the weight value becomes stable and not nearly-zero, the scale compares the value. It does not compare on an unstable condition.

Caution

- The upper limit value (HI) must be greater than the lower limit value (LO).
- The parameters of the upper limit value (HI) and the final value (HI) use the same memory. The parameters of the lower limit value (LO) and the preliminary value (OK) use the same memory.
- The upper/lower comparator function, the simple batch function and the full/dribble batch function can not be used at the same time because these parameters use the common memory.

11.1. Preparation (Setting Parameters)

Step 1 Turn off the display.

Press and hold the **ZERO** key and press the **ON/OFF** key. The function table is displayed.

Step 2 Press the **ENTER** key to display an item of the comparator function (**F6**).

Step 3 Select a parameter of the comparator function (**F6 0** to **F6 7**) with the **^** key.

Step 4 Press the **ENTER** key and the **F** key to display **End**. Press the **ENTER** key to return to the normal weighing mode.

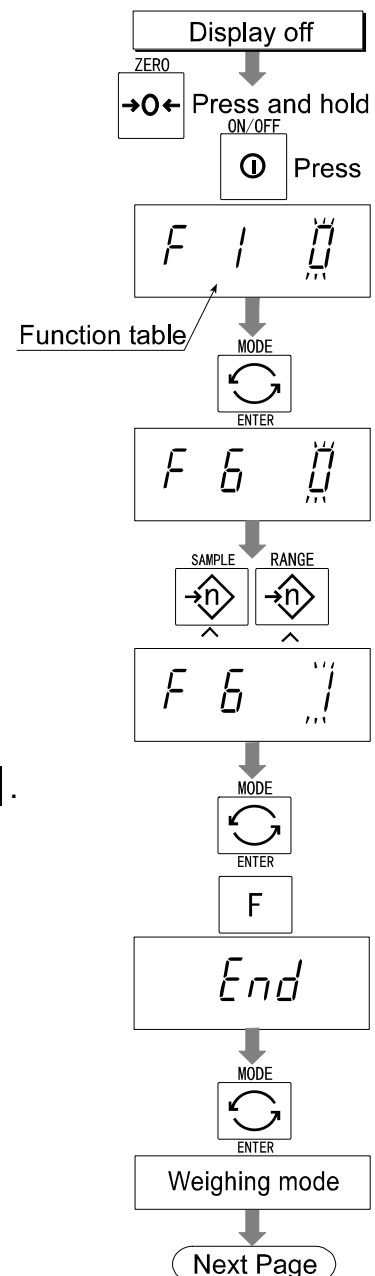

Step 5 If either of **F6 0**, **F6 2**, **F6 4**, **F6 6** has been selected, press the **SET** key to use the comparator.

Step 6 Press the **MODE** key to display the blinking HI.

Step 7 Set the upper limit value using the following keys.
< key Selecting the figure to be changed.
^ key Changing the number of the figure.
F key Selecting the polarity (+,-).

Step 8 Press the **ENTER** key to store the new parameter and display the blinking LO.

Step 9 Set the lower limit value using the following keys.
< key Selecting the figure to be changed.
^ key Changing the number of the figure.
F key Selecting the polarity (+,-).

Step 10 Press the **ENTER** key to store the new parameter and return to the normal weighing mode.
 If the lower limit value is greater than the upper limit value, the scale returns to step 7.

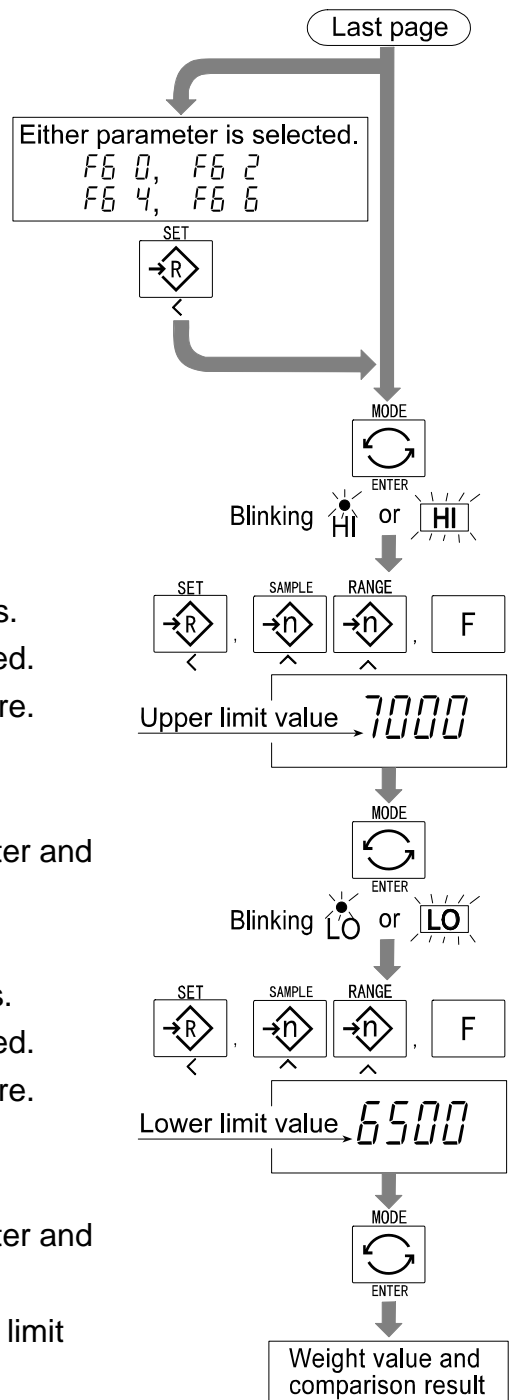

11.2. Operation and Performance (Examples)

Example 1

This example is set as follows:

Function table	F5 1	(The scale always compares the weight value even when the value is nearly-zero.)
Upper limit value (HI)	7.000 kg	
Lower limit value (LO)	6.500 kg	

Case

- The comparison starts when the scale is turned on.
- When the current value is less than 6.500kg, LO is displayed.
- When the current value is between 6.500kg and 7.000kg, OK is displayed.
- When the current value is greater than 7.000kg, HI is displayed.

Example 2

This example is set as follows:

Function table	F5 4	(When the SET key is pressed and the stability mark is displayed, the scale compares the current weight value with the upper limit value and the lower limit value immediately.)
Upper limit value (HI)	2.000 kg	
Lower limit value (LO)	-1.000 kg	

Case

- The comparison starts when the SET key is pressed and the stability mark is displayed.
- When the current value is less than -1.000kg, LO is displayed.
- When the current value is between -1.000kg and 2.000kg, OK is displayed.
- When the current value is greater than 2.000kg, HI is displayed.



12. Full/Dribble Batch Function

- This function changes the scale to a filling machine which sub-divides a bulk product (like grain) into loads of predetermined and virtually constant mass.
- To use this function, set the parameter of the "Comparator function ($F69$)", " Full/dribble batch sub-function ($F100$ to $F103$)" in the function table, final value (HI), preliminary value (OK) and zero band (LO).
- Install option OP-03 or OP-04 to use the relay output of the full/dribble batch function.
- In case of building up a filling machine with a scale and hopper, the performance is as follows:
- The settings are stored in the scale even if the power is removed. (Refer to Caution on the next page.)

Procedure

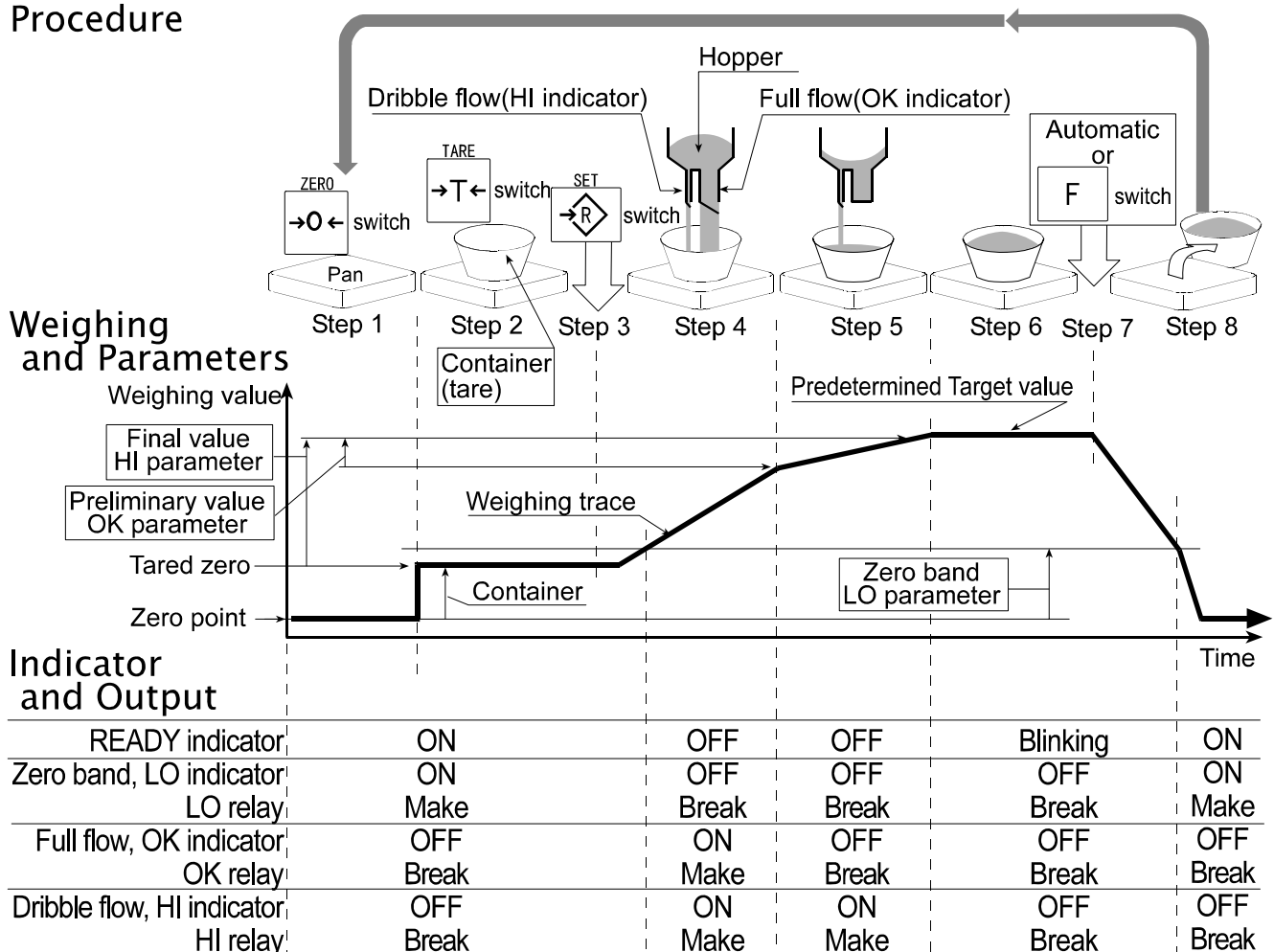

	Zero band indicator/ LO relay output	Preliminary value indicator/ OK relay output	Final value indicator/ HI relay output
Gross < Zero band (Zero detection Level)	ON / Make	OFF / Break	OFF / Break
Net < Final - Preliminary	OFF / Break	ON / Make	ON / Make
Final - Preliminary \leq Net < Final	OFF / Break	OFF / Break	ON / Make
Final \leq Net	OFF / Break	OFF / Break	OFF / Break

Caution

- ❑ The comparison of the full/dribble batch function can not be restored. (One way sequence). If the weight value becomes less than the final value after the value reached a predetermined target value, neither HI nor LO is on.
- ❑ The parameters of the upper limit value (HI) and the final value (HI) use the same memory. The parameters of the lower limit value (LO) and the preliminary value (OK) use the same memory.
- ❑ The upper/lower comparator function, the simple batch function and the full/dribble batch function can not be used at the same time because these parameters use the common memory.
- ❑ Set the zero band greater than the tare value.

Operation

- ❑ The batch process starts when the **[SET]** key is pressed.
- ❑ When a parameter from **[F 10 0]** or **[F 10 2]** of the full/dribble batch sub-function is selected, the **[F]** key functions as the finish key.

Parameter List and Word Definition

- ❑ The "gross" is a total weight value (the tare value is not subtracted).
- ❑ The "net" is a measurement value with the tare value subtracted from the gross.
- ❑ The "zero band" means the zero detection level.
- ❑ The "zero point" is the fundamental starting point to weigh anything.

Comparator

Function table	Description
<i>F 6 9</i>	Full/dribble batch function.

Full/dribble batch sub-function

Function table	Description
<i>F 10 0</i>	When the [F] key is pressed after final value is reached, the current process is finished.
<i>F 10 1</i>	When the stability mark is displayed after final value is reached, the current process is finished.
<i>F 10 2</i>	When the [SET] key is pressed, the scale automatically tares and starts the full/dribble batch process. When the [F] key is pressed after final value is reached, the current process is finished.
<i>F 10 3</i>	When the [SET] key is pressed, the scale automatically tares and starts the full/dribble batch process. When the stability mark is displayed after final value is reached, the current process is finished.

Hold

Function table	Description
<i>F 12 0</i>	The hold function is not used.

12.1. Preparation (Setting Parameters)

Step 1 Turn off the display.

Press and hold the **ZERO** key and press the **ON/OFF** key.
The function table is displayed.

Step 2 Press the **ENTER** key to display an item of the comparator function (**F 6**).

Step 3 Select a parameter of the full/dribble batch function (**F 6 9**) with the **^** key.

Step 4 Press the **ENTER** key to store the new parameter and display an item of the full/dribble batch sub-function (**F 10**).

Step 5 Select a parameter of the full/dribble batch sub-function (**F 10 0** to **F 10 3**) with the **^** key.

Step 6 Press the **ENTER** key and the **F** key to display **End**.

Step 7 Press the **ENTER** key to return to the normal weighing mode.

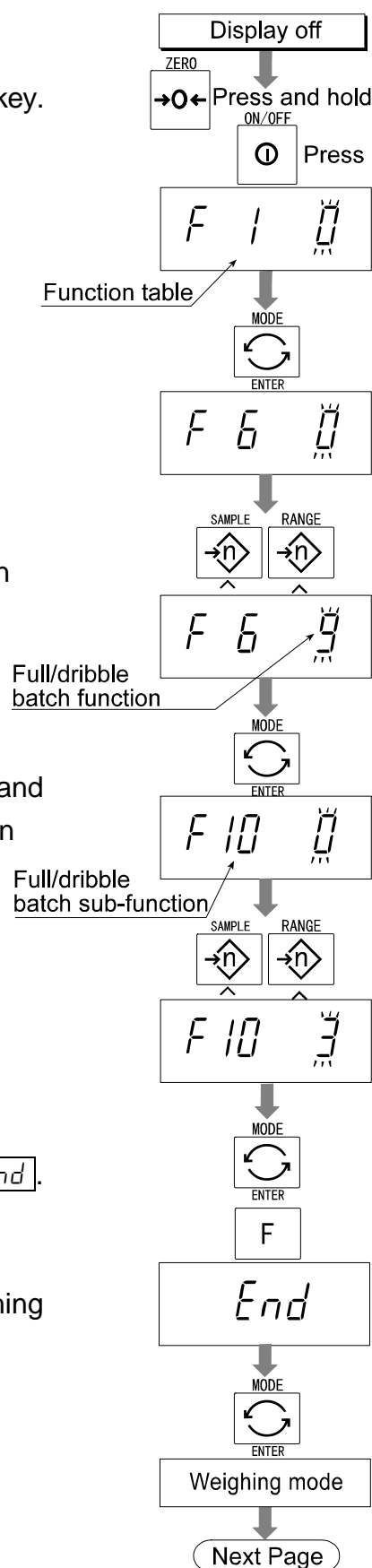

Step 8 Press the **MODE** key to display the blinking HI (of the final value).

Step 9 Set the final value using the following keys.
< key Selecting the figure to be changed.
^ key Changing the number of the figure.

Step 10 Press the **ENTER** key to store the new parameter and display the blinking OK (of preliminary value).

Step 11 Set the preliminary value using the following keys.
< key Selecting the figure to be changed.
^ key Changing the number of the figure.

Step 12 Press the **ENTER** key to store the new parameter and display the blinking LO (of zero band).

Step 13 Set a zero band which is greater than the tare value, using the following keys.
< key Selecting the figure to be changed.
^ key Changing the number of the figure.

Step 14 Press the **ENTER** key to store the new parameter and return to the normal weighing mode.

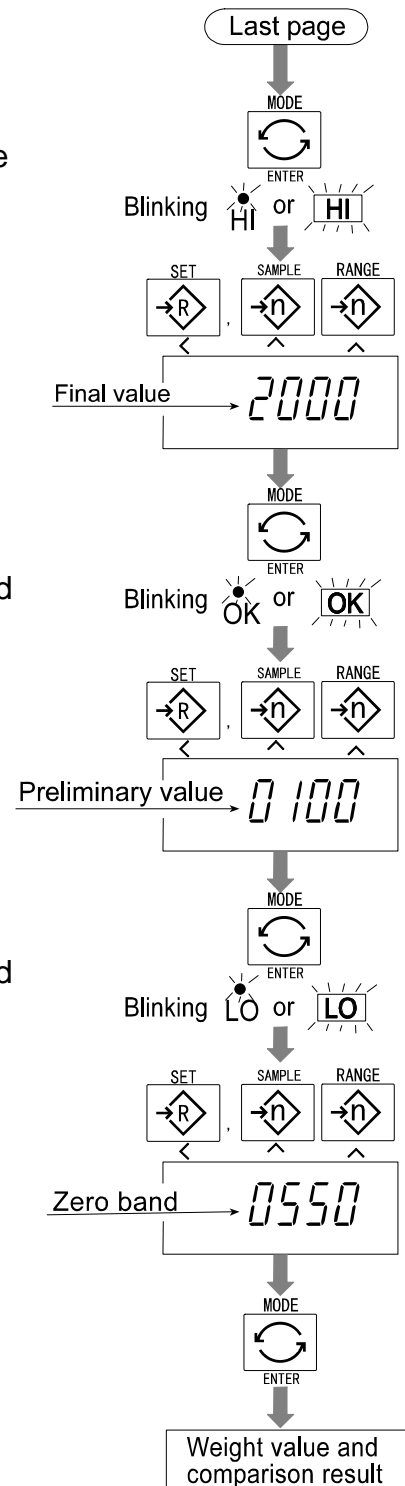



13. Simple Batch Function

- This function compares a weight value with the final value, preliminary value and zero band for the full/dribble batch function. The result is indicated by zero band (LO indicator), full flow (HI indicator) and dribble flow (OK indicator). Even if the weight value is increasing or decreasing, this function can compare it.
- To use this function, set the parameters of the "Simple batch function ($\overline{F6} \overline{B}$)" in the function table, final value (HI), preliminary value (OK) and zero band (LO).
- Install option OP-03 or OP-04 to use the relay output of the comparison.
- Install option OP-03 to use the buzzer output of the comparator.
- The settings are stored in the scale even if the power is removed. (Refer to Caution on the next page.)

Weighing and Parameters

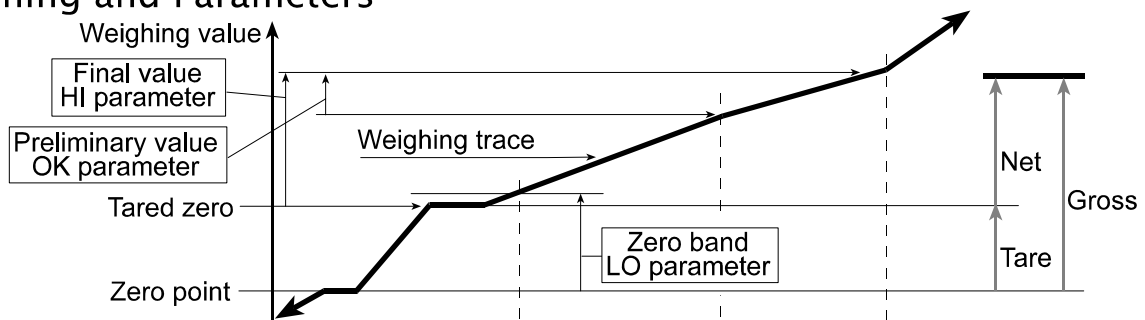

Indicator and Output

Zero band, LO indicator	ON	OFF	OFF	OFF
LO relay output	Make	Break	Break	Break
Preliminary, OK indicator	OFF	OFF	ON	ON
OK relay output	Break	Break	Make	Make
Final, HI indicator	OFF	OFF	OFF	ON
HI relay output	Break	Break	Break	Make

Comparison Condition

- Gross < Zero band LO is displayed and output.
- Final - Preliminary \leq Net OK is displayed and output.
- Final \leq Net OK, HI are displayed and output.

Parameter List and Word Definition

- The "gross" is a total weight value (the tare value is not subtracted).
- The "net" is a measurement value with the tare value subtracted from the gross.
- The "tare" is an item placed on the pan and its mass is subtracted from the gross.
- The "zero band" means the zero detection level.
- The "zero point" is the fundamental starting point to weigh anything.

Function table	Description
$\overline{F6} \overline{B}$	Simple batch function

Caution

- The parameters of the upper limit value (HI) and a final value (HI) use the same memory. The parameters of the lower limit value (LO) and the preliminary value (OK) use the same memory.
- The upper/lower comparator function, the simple batch function and the full/dribble batch function can not be used at the same time because these parameters use the common memory.

13.1. Preparation (Setting Parameters)

Step 1 Turn off the display.

Press and hold the **ZERO** key and press the **ON/OFF** key.
The function table is displayed.

Step 2 Press the **ENTER** key to display an item of the comparator function (**F6**).

Step 3 Select a parameter of the simple batch function (**F6 B**) with the **^** key.

Step 4 Press the **ENTER** key and the **F** key to display **End**.

Step 5 Press the **ENTER** key to return to the normal weighing mode.

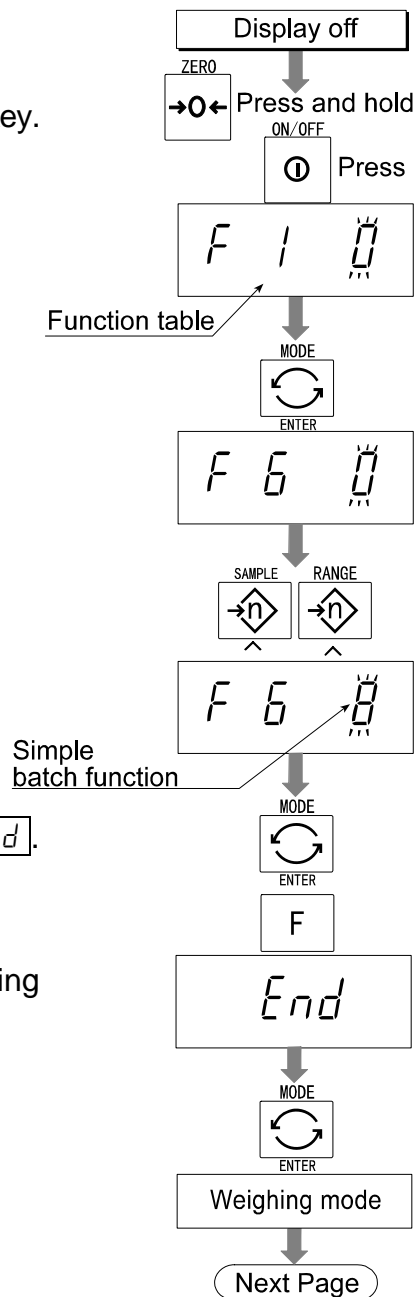

Step 6 Press the **MODE** key to display the blinking HI (of the final value).

Step 7 Set the final value using the following keys.
 \leftarrow key Selecting the figure to be changed.
 \wedge key Changing the number of the figure.

Step 8 Press the **ENTER** key to store the new parameter and display the blinking OK (of preliminary value).

Step 9 Set the preliminary value using the following keys.
 \leftarrow key Selecting the figure to be changed.
 \wedge key Changing the number of the figure.

Step 10 Press the **ENTER** key to store the new parameter and display the blinking LO (of zero band).

Step 11 Set the zero band using the following keys.
 \leftarrow key Selecting the figure to be changed.
 \wedge key Changing the number of the figure.

Step 12 Press the **ENTER** key to store the new parameter and return to the normal weighing mode.

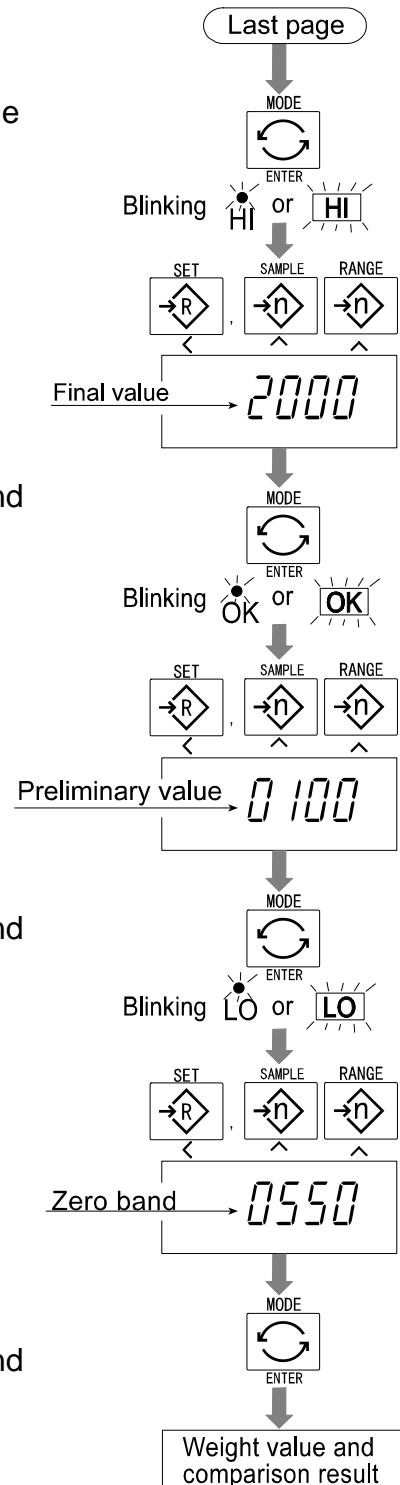

13.2. Operation and Performance (Examples)

Step 1 Select the parameter **FB B** of the function table.

Step 2 Set the parameters of the final value, preliminary value and zero band.

Step 3 The comparison result is always displayed.

Comparison Condition

Gross	<	Zero band	LO is displayed and output.
Final - Preliminary	\cong	Net	OK is displayed and output.
Final	\cong	Net	OK, HI are displayed and output.



14. Calibration (Adjusting the Scale)

- The scale is an instrument which weighs the "weight" and displays its "mass". Calibration is the adjustment function so that the scale can weigh correctly.
- Three steps of calibration are available

Gravity Acceleration Correction ... The function to correct the scale's local gravity acceleration, so that the scale functions correctly when the calibrated scale has been moved to a distant place.
Refer to the "Gravity Acceleration Table" on the next page.

Calibration of the Zero Point The function to adjust the zero point, so that the zero point mark is displayed when there is nothing on the pan.

Comment The zero point is the fundamental starting point to weigh anything and influences the performance of scale.

Span Calibration..... The function to adjust the span with a calibrated mass, so that the scale can accurately weigh anything within the weighing capacity.

Comment Span means the range of weighing capacity. Use a calibration mass heavier than two thirds of the weighing capacity.

Caution

- **Check the accuracy of weighing periodically. Calibrate the scale, if it has been moved to another location or the environment has changed.**
- **Gravity acceleration correction is not required, when the scale is calibrated with the calibration mass at the place where the scale is used.**



14.1. Gravity Acceleration Table

Amsterdam	9.813 m/s ²	Manila	9.784 m/s ²
Athens	9.800 m/s ²	Melbourne	9.800 m/s ²
Auckland, NZ	9.799 m/s ²	Mexico	9.779 m/s ²
Bangkok	9.783 m/s ²	Milan	9.806 m/s ²
Birmingham	9.813 m/s ²	New York	9.802 m/s ²
Brussels	9.811 m/s ²	Oslo	9.819 m/s ²
Buenos Aires	9.797 m/s ²	Ottawa	9.806 m/s ²
Calcutta	9.788 m/s ²	Paris	9.809 m/s ²
Chicago	9.803 m/s ²	Rio de Janeiro	9.788 m/s ²
Copenhagen	9.815 m/s ²	Rome	9.803 m/s ²
Cyprus	9.797 m/s ²	San Francisco	9.800 m/s ²
Djakarta	9.781 m/s ²	Singapore	9.781 m/s ²
Frankfurt	9.810 m/s ²	Stockholm	9.818 m/s ²
Glasgow	9.816 m/s ²	Sydney	9.797 m/s ²
Havana	9.788 m/s ²	Tainan	9.788 m/s ²
Helsinki	9.819 m/s ²	Taipei	9.790 m/s ²
Kuwait	9.793 m/s ²	Tokyo	9.798 m/s ²
Lisbon	9.801 m/s ²	Vancouver, BC	9.809 m/s ²
London (Greenwich)	9.812 m/s ²	Washington, DC	9.801 m/s ²
Los Angeles	9.796 m/s ²	Wellington, NZ	9.803 m/s ²
Madrid	9.800 m/s ²	Zurich	9.807 m/s ²

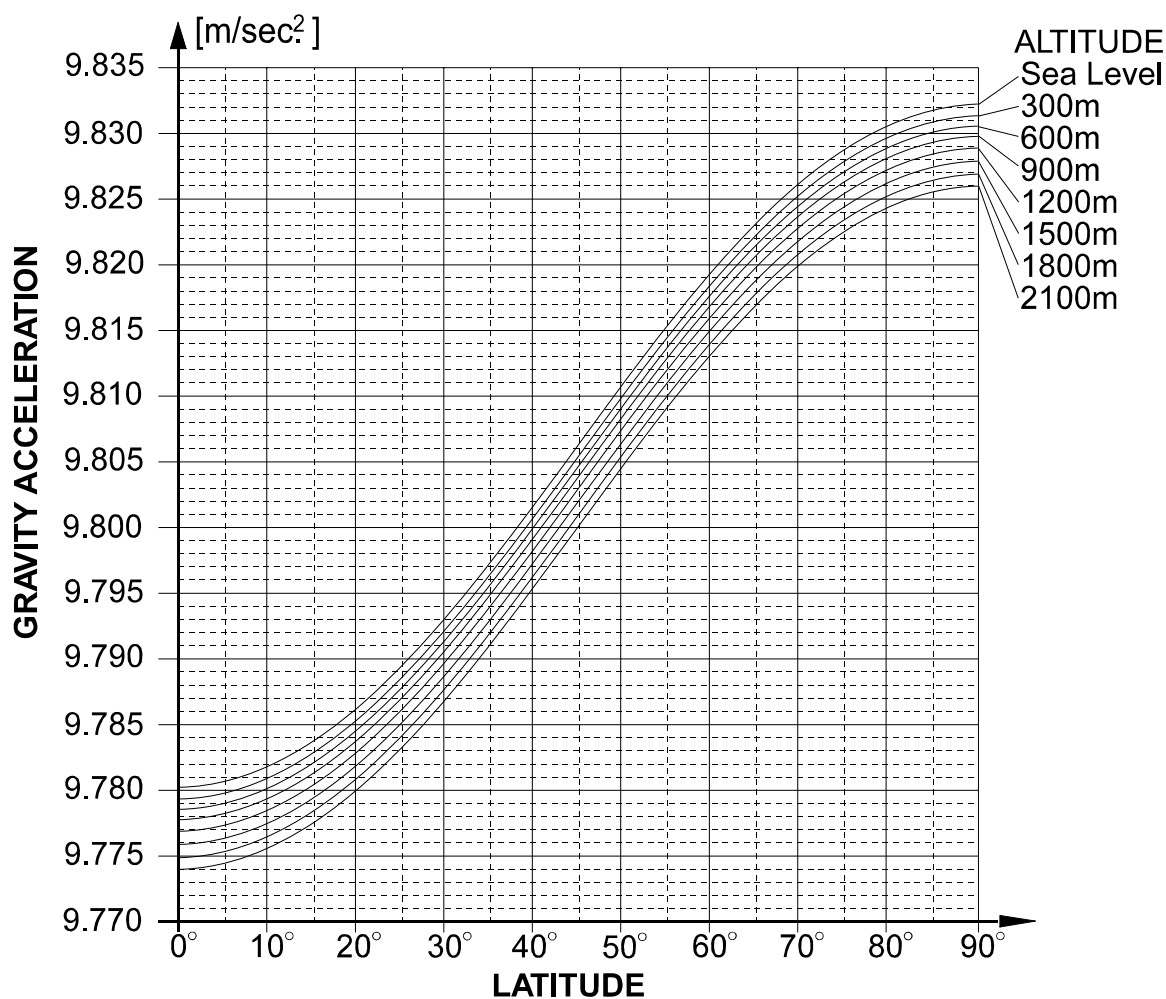



14.2. Complete Calibration Procedure

14.2.1. Gravity Acceleration Correction

- Step 1 Turn on the display.
Open the rear cover of the display unit. Locate the **CAL** switch inside.
Press and hold the **CAL** switch to enter the calibration mode.
Then **CAL 0** is displayed.
- Step 2 Press the **ZERO** key to enter the gravity acceleration correction mode.
- Step 3 Set your local gravity acceleration using the following keys.

	key	Selecting the figure to be changed.
	key	Changing the number of the figure.
- Step 4 Press the **ENTER** key to store the new value.
Then **CAL 0** is displayed.
- Step 5 Press the **CAL** switch again. Then the scale returns to the normal weighing mode.

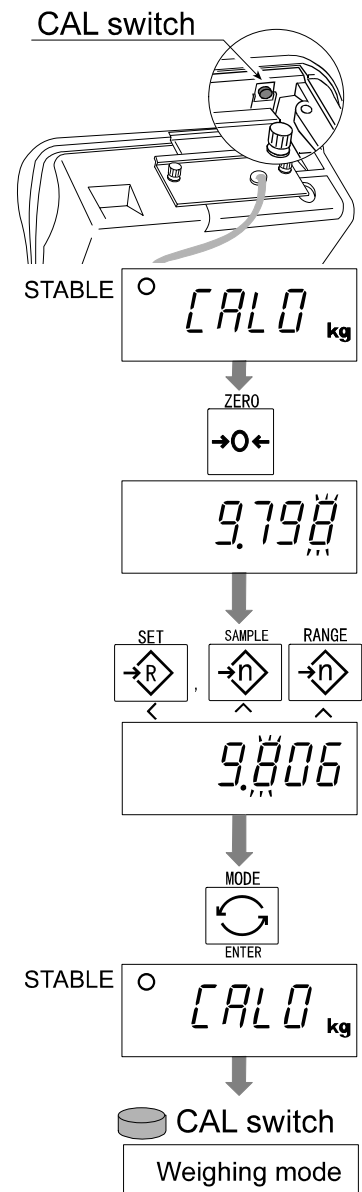

14.2.2. Preparation

- Step 6 Confirm the environmental conditions as follows:
Maintain a constant temperature and stable power.
Install the scale on a solid floor where there is no draft, vibration, strong magnetic fields or direct sunlight.
Refer to "4.1. Installing the Scale".
- Step 7 Keep the display turned on for at least 30 minutes to warm up the scale.

14.2.3. Calibration of the Zero Point

- Step 8 After 30-minute warm up, press and hold the **CAL** switch to enter the calibration mode. Then the **CAL 0** is displayed.
- Step 9 Confirm that nothing is placed on the pan. Wait for the stability mark to be displayed. Press the **ENTER** key. The scale stores the current condition as the zero point.
- Step 10 The scale displays **SPn 1** for several seconds. Calibration of the zero point is finished. To exit the calibration mode, proceed to step 14.

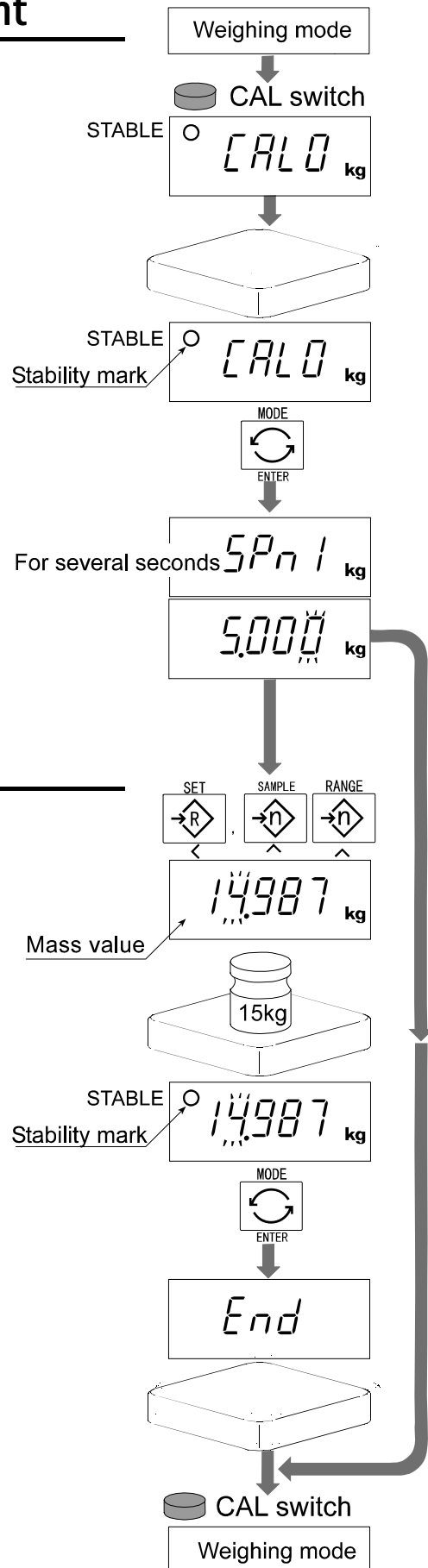

14.2.4. Span Calibration

- Step 11 Set the value of the calibration mass using the following keys. (The initial value depends on the scale model.)
- <** key Selecting the figure to be changed.
 - ^** key Changing the number of the figure.
- Step 12 Place the mass on the pan which was set at step 11. Wait for the stability mark to be displayed. Press the **ENTER** key. The scale then calculates the span and stores it.
- Step 13 The scale displays **End**. Remove the mass from the pan.
- Step 14 Press the **CAL** switch to return to the normal weighing mode.

Note
The pan shape depends on the scale model.



15. Function Table

- ❑ The function table is used to store and refer items that determine the performance of the scale. Each item has a parameter.
- ❑ The parameters are stored in the scale even if the power is removed.

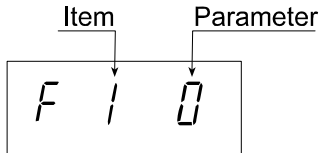

15.1. Parameter Setting Procedure

Step 1 Turn off the display.

Press and hold the **ZERO** key and press the **ON/OFF** key.
The function table is displayed.

Step 2 Set parameters for each item using the following keys.

- ▲** key Selecting the parameter of an item.
- ◀** key Selecting a figure.
- F** key Proceeding to step 3 without storing the parameter.
- ENTER** key Storing a parameter for the current item and proceeding to the next item.

Step 3 When the end of the table is reached, **End** is displayed.

Step 4 Press the **ENTER** key to store the new parameters and return to the normal weighing mode.

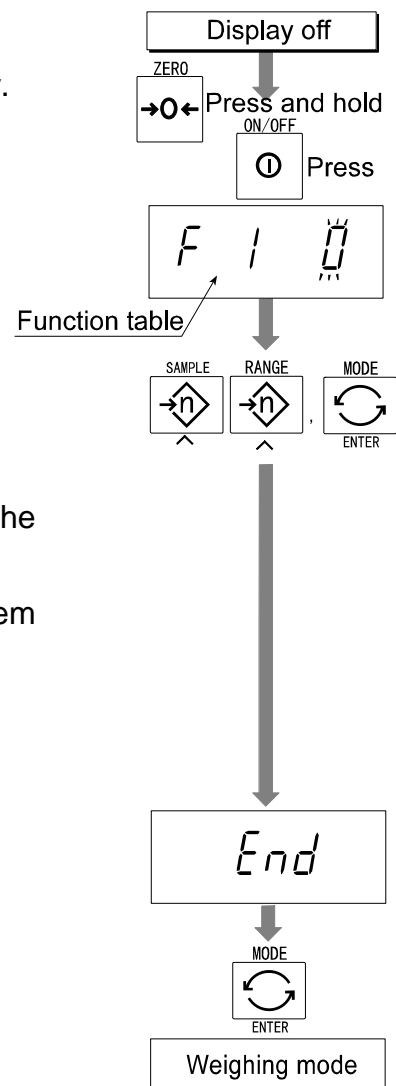

15.2. Parameter List

Item	Display	Description
Automatic turning off		The type L scale is turned off after 5 minutes of no operation, when zero is displayed.
	F1 0 #	Not used
	F1 1	Used
Weighing range		Selects how to change the weighing range for HV-L and HV-G series.
	F2 0 #	Automatic range
	F2 1	Manual range
Unit		Selects the first unit at the time when the scale turns on.
	F3 0 #	Kg
	F3 1	Lb
	F3 2	Oz
	F3 3	lb-oz
Baud rate		Selects the transmission rate of the serial interface (RS-232C/ 422/485).
	F4 0 #	2400 bps
	F4 1	4800 bps
	F4 2	9600 bps
Output mode		Selects the mode for the serial interface (RS-232C/ 422/485).
	F5 0 #	Stream mode. (Refer to "16.2. Stream Mode")
	F5 1	Command mode. (Refer to "16.3. Command Mode")
	F5 2	A data is output, when the PRINT key is pressed.
	F5 3	Auto-print + When the display becomes a positive stable value and not nearly-zero, the scale outputs the data automatically. Next output can be performed after the display becomes nearly-zero or a negative value.
	F5 4	Auto-print +/- When the display becomes a stable value and not nearly-zero, the scale outputs the data automatically. Next output can be performed after the display becomes nearly-zero.
	F5 5	At each end of full/dribble batch function, the data is output.
Comparator		Selects the comparator mode.
	F6 0 #	Press the SET key to always compare the current weight value. Press the SET key again to stop the comparison.
	F6 1	The scale always compares the weight value.
	F6 2	Press the SET key to always compare the weight value when not nearly-zero. Press the SET key again to stop the comparison.
	F6 3	The scale always compares the weight value when not nearly-zero.

"#" :factory settings. The "nearly-zero" is within ± 5 digits from zero point in the unit of kg.

Item	Display	Description
Comparator	F6 4	When the weight value becomes stable after the [SET] key is pressed, the scale compares the weight value. It does not compare on an unstable condition. Press the [SET] key again to stop the comparison.
	F6 5	When the weight value is stable, the scale compares the weight value. It does not compare on an unstable condition.
	F6 6	When the weight value becomes stable and not nearly-zero after the [SET] key is pressed, the scale compares the weight value. It does not compare on an unstable condition. Press the [SET] key again to stop the comparison.
	F6 7	When the weight value becomes stable and not nearly-zero, the scale compares the value. It does not compare on an unstable condition.
	F6 8	Simple batch function. (Refer to "13. Simple Batch Function")
	F6 9	Full/dribble batch function. (Refer to "12. Full/Dribble Batch Function")
Buzzer	Selects the condition of the buzzer on option OP-03 by comparator function or full/dribble batch function.	
	F7 0 #	No buzzer.
	F7 1	The buzzer sounds at LO.
	F7 2	The buzzer sounds at OK.
	F7 3	The buzzer sounds at LO and OK.
	F7 4	The buzzer sounds at HI.
	F7 5	The buzzer sounds at LO and HI.
	F7 6	The buzzer sounds at OK and HI.
	F7 7	The buzzer sounds at LO, OK and HI.
F7 8	The buzzer sounds at the end of the full/dribble batch process.	
Accumulation function	Select the condition of the accumulation function	
	F8 0 #	Accumulation function not used.
	F8 1	The scale accumulates the data, if the [F] key is pressed, when the display is a positive stable value and not nearly-zero. The next accumulation can be performed after the display becomes nearly-zero or a negative value.
	F8 2	The scale accumulates the data, if the [F] key is pressed, when the display is a stable value and not nearly-zero. The next accumulation can be performed after the display becomes nearly-zero.
F8 3	When the display is a positive stable value and not nearly-zero, the scale accumulates the data automatically. The next accumulation can be performed after the display becomes nearly-zero or a negative value. Use: After weighing the first unit sample, one after another, it records the total count and total weight value.	

"#": factory settings. The "nearly-zero" is within ± 5 digits from zero point in the unit of kg.

Item	Display	Description
Accumulation function	<i>F8 4</i>	When the display is a stable value and not nearly-zero, the scale accumulates the data automatically. The next accumulation can be performed after the display becomes nearly-zero. Use Recording the number and mass of articles removed from the pan. (Place the articles on the pan. Press the TARE key at each removal.)
	<i>F8 5</i>	At each end of the full/dribble batch function, the scale accumulates the data automatically. Use Packaging articles like a powder, it is used for recording the bag number and total mass.
Print mode	Selects the printing condition. Option OP-06 for type V is required.	
	<i>F9 0 #</i>	No print.
	<i>F9 1</i>	Press the PRINT key to output the data.
	<i>F9 2</i>	Auto-print + When the display becomes a positive stable value and not nearly-zero, the scale outputs the data automatically. Next output can be performed after the display becomes nearly-zero or negative value.
	<i>F9 3</i>	Auto-print +/- When the display becomes a stable value and not nearly-zero, the scale outputs the data automatically. Next output can be performed after the display becomes nearly-zero.
	<i>F9 4</i> <i>F9 5</i>	At each end of full/dribble batch function, the data is output. When the accumulation function is used, the data is output.
Full/Dribble batch sub-function	Selects the details of the full/dribble batch function (<i>F6 9</i>)	
	<i>F10 0 #</i>	When the F key is pressed after final value is reached, the current process is finished.
	<i>F10 1</i>	When the stability mark is displayed after final value is reached, the current process is finished automatically.
	<i>F10 2</i> <i>F10 3</i>	When the SET key is pressed, the scale automatically tares and starts the full/dribble batch process. When the F key is pressed after final value is reached, the current process is finished When the SET key is pressed, the scale automatically tares and starts the full/dribble batch process. When the stability mark is displayed after final value is reached, the current process is finished.
Address	Select the address for RS-422 / RS-485 for option OP-04	
	<i>F1100 #</i> <i>F11 01</i> to <i>F11 99</i>	Use Addresses from 01 to 99 are available. Scales are assigned unique addresses and are controlled by the computer. (RS-232C should be set to "00".)

"#": factory settings. The "nearly-zero" is within ± 5 digits from zero point in the unit of kg.

Item	Display	Description
Hold		Selects the method to hold the current weight value. When the weight value becomes nearly-zero or changes more than 25% +30 digits, hold display is canceled.
	F 12 0 #	Not used
	F 12 1	The hold function is ON or OFF alternately by the \boxed{F} key.
	F 12 2	When the stability mark is displayed, the display is held.
Averaging		Selects readability and response.
	F 13 0 #	Fast response, sensitive value
	F 13 2	Slow response, stable value
Precision of unit mass		Selects a storable minimum unit mass in the counting mode.
	F 14 0 #	Stores a unit mass in the unit of a digit.
	F 14 1	Stores a unit mass in the unit of one eighth digit.
	F 14 2	Stores a unit mass, if the total of sample mass is greater than 5 digits.
Format		Refer to "16.1. Data Format".
	F 15 0 #	Format 1 (A&D general format for scales, balances)
	F 15 1	Format 2 (Older HV-A/ HW-A format)
	F 15 2	Not used
Number of carriage return for the printer		Used when Type V scale is equipped with option OP-06, a built-in impact dot matrix printer.
	F 16 0 #	Selects the number of carriage return after the data is printed.
	F 16 1 # to F 16 9	
Date		Option OP-06 for type V is required. Use Printout of date. Caution Date is not updated. Printout of the management number for the scale.
	F 17 000000 #	The function number "F 17" is not displayed. No printout
	others	The relation between printout and display is as follows: Display 99072 1 Printout 99/07/21

"#": factory settings

The "nearly-zero" is within ± 5 digits from zero point in the unit of kg.

The "digit" is a unit of display, and is equivalent to the minimum measurable mass.



16. RS-232C Serial Interface

Note When the RS-232C serial interface is used, be sure to set the “Address ()” to “()”.

- RS-232C interface has the following two modes.
 - Stream mode Outputs data continuously and can be used to print data.
 - Command mode Controls the scale using commands from a computer.
- To use RS-232C interface, set the parameters of the “Baud rate ()”, “ Output mode ()”, “ Format ()” in the function table.
- Optional cables are available as follows:
 - AX-KO577A-200 RS-232C cable, D-sub 25 pin, 2 m
 - AX-KO1786-200 RS-232C cable, D-sub 9 pin, 2 m
- Transmission system EIA RS-232C
- Transmission Asynchronous, bi-directional, half-duplex
- Data format
 - Baud rate 2400, 4800, 9600 bps
 - Data 7 bits
 - Parity 1 bit, Even
 - Start bit 1 bit
 - Stop bit 1 bit
 - Code ASCII
 - Terminator CR LF (CR: 0Dh, LF: 0Ah)
- Pin connections

Pin No.	Signal name	Direction	Description
1	-		
2	RXD	Input	Receive data
3	TXD	Output	Transmit data
4	-		
5	SG	-	Signal ground
6	-		
7	DSR	Output	Data set ready
8	-	-	

- Circuits

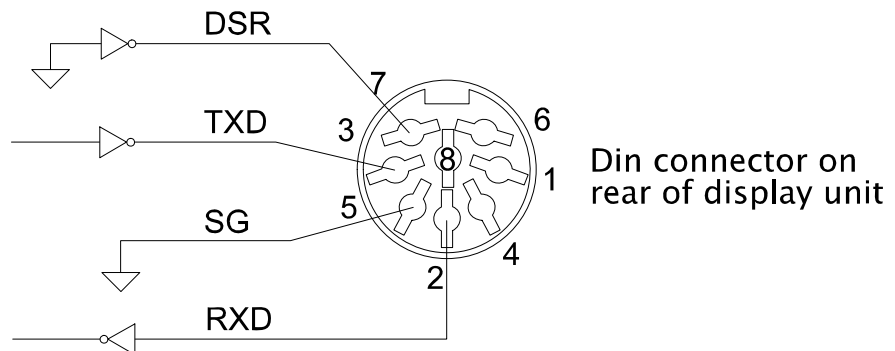

- Adaptable connector DIN 8 pin (TCP0586)



16.1. Data Format

Bit Format

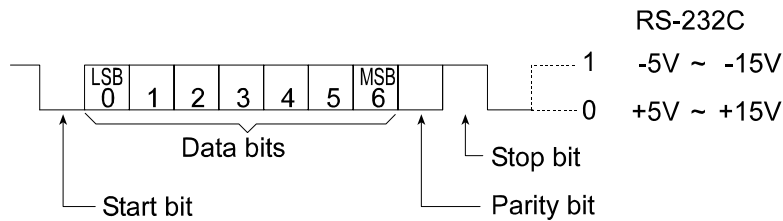

Format 1

- There are four headers for the type of data and weighing condition.

Stable weighing data	S T	Unstable weighing data	U S
Stable counting data	Q T	Out of range (Over)	O L
- The weight value consists of 9 characters including decimal point and polarity.
- The polarity is always output.
- There are three units. The unit is 3 characters.
- In case of "out of range", numbers become all 9's.
- The terminator is always output as CR LF.

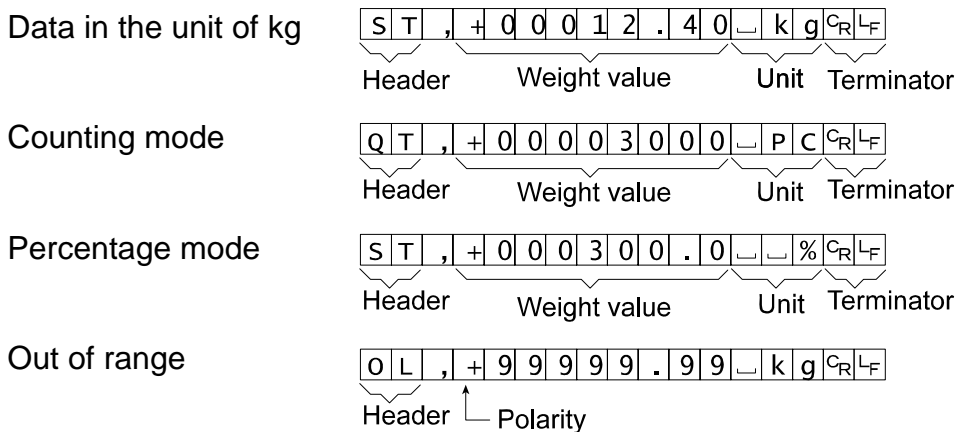

- Definition of symbols

CR (carriage return)	C R	LF (line feed)	L F
0Dh		0Ah	
Space	_		
20h			

Format 2

- There are four headers for the type of data and weighing condition.

Stable weighing data	S	T	Unstable weighing data	U	S
Stable counting data	Q	T	Out of range	O	L
- The weight value consists of 7 characters including decimal point and polarity.
- The polarity is always output.
- There are three units. The unit is 2 characters.
- In case of "out of range", numbers become all 9's.
- The terminator is always output as CR LF.

Caution

When the data is longer than 7 characters in the counting, accumulation function or percentage mode, the overflow is ignored.

Data in the unit of kg	<table style="border-collapse: collapse; width: 100%; text-align: center;"> <tr> <td style="border: 1px solid black; padding: 2px 5px;">S</td><td style="border: 1px solid black; padding: 2px 5px;">T</td><td style="border: 1px solid black; padding: 2px 5px;">,</td><td style="border: 1px solid black; padding: 2px 5px;">+</td><td style="border: 1px solid black; padding: 2px 5px;">0</td><td style="border: 1px solid black; padding: 2px 5px;">0</td><td style="border: 1px solid black; padding: 2px 5px;">2</td><td style="border: 1px solid black; padding: 2px 5px;">.</td><td style="border: 1px solid black; padding: 2px 5px;">4</td><td style="border: 1px solid black; padding: 2px 5px;">0</td><td style="border: 1px solid black; padding: 2px 5px;">k</td><td style="border: 1px solid black; padding: 2px 5px;">g</td><td style="border: 1px solid black; padding: 2px 5px;">C_R</td><td style="border: 1px solid black; padding: 2px 5px;">L_F</td> </tr> <tr> <td colspan="3" style="border: none;">Header</td> <td colspan="7" style="border: none;">Weight value</td> <td colspan="2" style="border: none;">Unit</td> <td colspan="2" style="border: none;">Terminator</td> </tr> </table>	S	T	,	+	0	0	2	.	4	0	k	g	C _R	L _F	Header			Weight value							Unit		Terminator	
S	T	,	+	0	0	2	.	4	0	k	g	C _R	L _F																
Header			Weight value							Unit		Terminator																	
Counting mode	<table style="border-collapse: collapse; width: 100%; text-align: center;"> <tr> <td style="border: 1px solid black; padding: 2px 5px;">Q</td><td style="border: 1px solid black; padding: 2px 5px;">T</td><td style="border: 1px solid black; padding: 2px 5px;">,</td><td style="border: 1px solid black; padding: 2px 5px;">+</td><td style="border: 1px solid black; padding: 2px 5px;">0</td><td style="border: 1px solid black; padding: 2px 5px;">0</td><td style="border: 1px solid black; padding: 2px 5px;">3</td><td style="border: 1px solid black; padding: 2px 5px;">0</td><td style="border: 1px solid black; padding: 2px 5px;">0</td><td style="border: 1px solid black; padding: 2px 5px;">0</td><td style="border: 1px solid black; padding: 2px 5px;">P</td><td style="border: 1px solid black; padding: 2px 5px;">C</td><td style="border: 1px solid black; padding: 2px 5px;">C_R</td><td style="border: 1px solid black; padding: 2px 5px;">L_F</td> </tr> <tr> <td colspan="3" style="border: none;">Header</td> <td colspan="7" style="border: none;">Weight value</td> <td colspan="2" style="border: none;">Unit</td> <td colspan="2" style="border: none;">Terminator</td> </tr> </table>	Q	T	,	+	0	0	3	0	0	0	P	C	C _R	L _F	Header			Weight value							Unit		Terminator	
Q	T	,	+	0	0	3	0	0	0	P	C	C _R	L _F																
Header			Weight value							Unit		Terminator																	
Percentage mode	<table style="border-collapse: collapse; width: 100%; text-align: center;"> <tr> <td style="border: 1px solid black; padding: 2px 5px;">S</td><td style="border: 1px solid black; padding: 2px 5px;">T</td><td style="border: 1px solid black; padding: 2px 5px;">,</td><td style="border: 1px solid black; padding: 2px 5px;">+</td><td style="border: 1px solid black; padding: 2px 5px;">0</td><td style="border: 1px solid black; padding: 2px 5px;">3</td><td style="border: 1px solid black; padding: 2px 5px;">0</td><td style="border: 1px solid black; padding: 2px 5px;">0</td><td style="border: 1px solid black; padding: 2px 5px;">.</td><td style="border: 1px solid black; padding: 2px 5px;">0</td><td style="border: 1px solid black; padding: 2px 5px;">_</td><td style="border: 1px solid black; padding: 2px 5px;">%</td><td style="border: 1px solid black; padding: 2px 5px;">C_R</td><td style="border: 1px solid black; padding: 2px 5px;">L_F</td> </tr> <tr> <td colspan="3" style="border: none;">Header</td> <td colspan="7" style="border: none;">Weight value</td> <td colspan="2" style="border: none;">Unit</td> <td colspan="2" style="border: none;">Terminator</td> </tr> </table>	S	T	,	+	0	3	0	0	.	0	_	%	C _R	L _F	Header			Weight value							Unit		Terminator	
S	T	,	+	0	3	0	0	.	0	_	%	C _R	L _F																
Header			Weight value							Unit		Terminator																	
Out of range	<table style="border-collapse: collapse; width: 100%; text-align: center;"> <tr> <td style="border: 1px solid black; padding: 2px 5px;">O</td><td style="border: 1px solid black; padding: 2px 5px;">L</td><td style="border: 1px solid black; padding: 2px 5px;">,</td><td style="border: 1px solid black; padding: 2px 5px;">+</td><td style="border: 1px solid black; padding: 2px 5px;">9</td><td style="border: 1px solid black; padding: 2px 5px;">9</td><td style="border: 1px solid black; padding: 2px 5px;">9</td><td style="border: 1px solid black; padding: 2px 5px;">.</td><td style="border: 1px solid black; padding: 2px 5px;">9</td><td style="border: 1px solid black; padding: 2px 5px;">9</td><td style="border: 1px solid black; padding: 2px 5px;">k</td><td style="border: 1px solid black; padding: 2px 5px;">g</td><td style="border: 1px solid black; padding: 2px 5px;">C_R</td><td style="border: 1px solid black; padding: 2px 5px;">L_F</td> </tr> <tr> <td colspan="3" style="border: none;">Header</td> <td style="border: none;">↑</td> <td colspan="10" style="border: none;">Polarity</td> </tr> </table>	O	L	,	+	9	9	9	.	9	9	k	g	C _R	L _F	Header			↑	Polarity									
O	L	,	+	9	9	9	.	9	9	k	g	C _R	L _F																
Header			↑	Polarity																									

- Definition of symbols

CR (carriage return)	C _R	LF (line feed)	L _F
0Dh		0Ah	
Space	_		
20h			



16.2. Stream Mode

- The scale outputs the current weighing data at the time the display is refreshed. The scale does not output data while in the setting mode.

Averaging of function table		Refresh rate
F13 0	Fast response Sensitive value	Approximately 7 times/s while the display is unstable, Approximately 4 times/s when the display is stable
F13 1	⇕	
F13 2	Slow response Stable value	Approximately 4 times/s

16.2.1. Preparation and Performance (Examples)

- Step 1 Turn off the display.
Press and hold the **ZERO** key and press the **ON/OFF** key. The function table is displayed.
- Step 2 Press the **ENTER** key to display **F4** ("Baud rate").
Select a parameter of "Baud rate" with the **▲** key.
- Step 3 Press the **ENTER** key to display **F5** ("Output mode").
Select "Stream mode (**F5 0**)" with the **▲** key.
- Step 4 Press the **ENTER** key to display **F15** ("Format").
Select "Format 1 (**F15 0**)" with the **▲** key.
- Step 5 Press the **ENTER** key to display **End**.
- Step 6 Press the **ENTER** key to store the new parameters.
The scale returns to the normal weighing mode and outputs the data continuously.

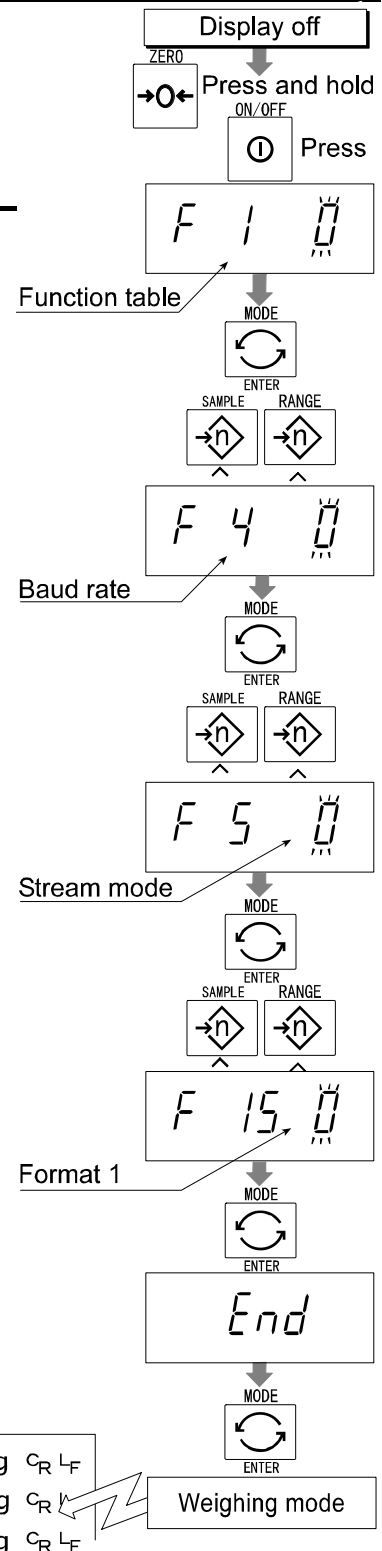



16.3. Command Mode

- The command mode is the function which can perform "outputting data", "controlling the scale" and "setting parameters" by a command transmitted from a computer

Caution Allow at least 500 milliseconds between commands.

16.3.1. Command List

The following explanation uses "Format 1 (F 15 0)"

Data output

The current weighing data is output.

Template Q

Command Q^{C_R}L_F

Reply ST,+00012.40_kg^{C_R}L_F

Selection of mode and unit

Selects the mode and unit. This is the same as the MODE key.

Template U

Command U^{C_R}L_F

Reply The scale changes mode and unit.

Zero

The current mass value is set to the zero point.

This is the same as the ZERO key.

Template Z

Command Z^{C_R}L_F

Reply The mass value becomes zero and the zero point mark is displayed.

Tare

With a tare (container) placed, the current mass value is set to zero, and the net is displayed. This is the same as the TARE key.

Template T

Command T^{C_R}L_F

Reply The current mass value becomes zero and the net mark is displayed.

Cancel of tare

The weight value becomes the gross and the net mark is turned off. (The tare value becomes zero.)

Template CT

Command CT^{C_R}L_F

Reply Gross is displayed and the net mark is turned off.

Preset tare

Tare value is set and the net is displayed.

The set value is a 5 digit numerical value with a polarity sign and does not contain a decimal point.

Template PT, [parameter]

Command

P	T	,	+	0	0	1	2	0	C _R	L _F
---	---	---	---	---	---	---	---	---	----------------	----------------

Reply Net is displayed and the net mark is displayed.

Upper limit value

The upper limit value is stored. The set value is a 5 digit numerical value with a polarity sign and does not contain a decimal point.

Template HI, [parameter]

Command

H	I	,	+	0	1	2	0	0	C _R	L _F
---	---	---	---	---	---	---	---	---	----------------	----------------

Reply The upper limit value is stored.

Caution The upper limit value must be greater than the lower limit value.

Lower limit value

The lower limit value is stored. The set value is a 5 digit numerical value with a polarity sign and does not contain a decimal point.

Template LO, [parameter]

Command

L	O	,	-	0	0	4	0	0	C _R	L _F
---	---	---	---	---	---	---	---	---	----------------	----------------

Reply The lower limit value is stored.

Caution The lower limit value must be less than the upper limit value.

Accumulation data output

Accumulated data is output.

Template A

Command

A	C _R	L _F
---	----------------	----------------

Reply

A	,	+	0	2	3	1	2	.	4	0	_	k	g	C _R	L _F
---	---	---	---	---	---	---	---	---	---	---	---	---	---	----------------	----------------

Accumulation count output

Number of accumulations is output.

Template N

Command

N	C _R	L _F
---	----------------	----------------

Reply

N	,	+	0	0	0	0	0	1	4	0	_	_	_	C _R	L _F
---	---	---	---	---	---	---	---	---	---	---	---	---	---	----------------	----------------

Reset of Accumulation data and Accumulation count

Accumulated data and number of accumulations are set to zero.

Template CA

Command

C	A	C _R	L _F
---	---	----------------	----------------

Reply Data and number of accumulations become zero.

Final value

The final value is stored. The set value is a 5 digit numerical value with a polarity sign and does not contain a decimal point.

Template S0, [parameter]

Command

S	0	,	+	0	2	0	0	0	C _R	L _F
---	---	---	---	---	---	---	---	---	----------------	----------------

Reply The value is stored.

Preliminary value

The preliminary value is stored. The set value is a 5 digit numerical value with a polarity sign and does not contain a decimal point.

Template S1, [parameter]

Command

S	1	,	+	0	0	2	0	0	C _R	L _F
---	---	---	---	---	---	---	---	---	----------------	----------------

Reply The value is stored.

Zero band

The zero band is stored. The set value is a 5 digit numerical value with a polarity sign and does not contain a decimal point.

Template S2, [parameter]

Command

S	2	,	+	0	0	5	0	0	C _R	L _F
---	---	---	---	---	---	---	---	---	----------------	----------------

Reply The value is stored.

16.3.2. Example of Setting Parameters

Step 1 Turn off the display.

Press and hold the **ZERO** key and press the **ON/OFF** key.
The function table is displayed.

Step 2 Press the **ENTER** key to display **F4** ("Baud rate").
Select a parameter of "Baud rate" with the **▲** key.

Step 3 Press the **ENTER** key to display **F5** ("Output mode").
Select "Command mode (**F5 1**)" with the **▲** key.

Step 4 Press the **ENTER** key to display **F15** ("Format").
Select "Format 1 (**F15 0**)" with the **▲** key.

Step 5 Press the **ENTER** key to display **End**.

Step 6 Press the **ENTER** key to store the new parameters.
The scale returns to the normal weighing mode.

Step 7 When the computer transmits a command, the scale replies.

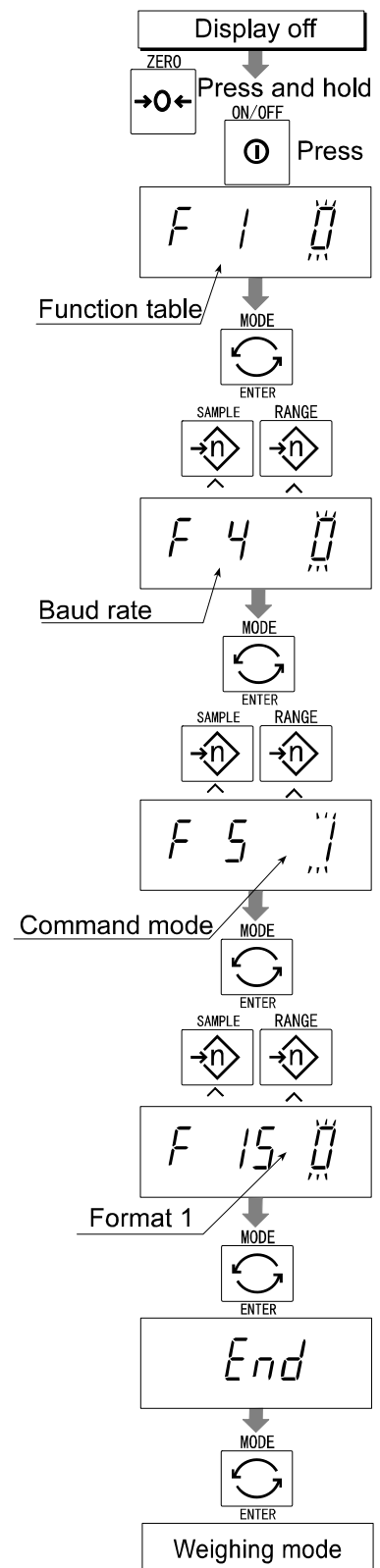



17. Options



17.1. Extension Load Cell Cable (OP-02)

- This cable is used for installing the indicator away from the base unit.
- This extension load cell cable is 5 m long.
- Refer to " 5.3. Removing the Pole" for how to remove the pole.

Caution

- **Calibrate the scale after connecting this cable.**
- **Do not connect more than two extension load cell cables.**

For models with weighing capacity of 10 kg to 200 kg

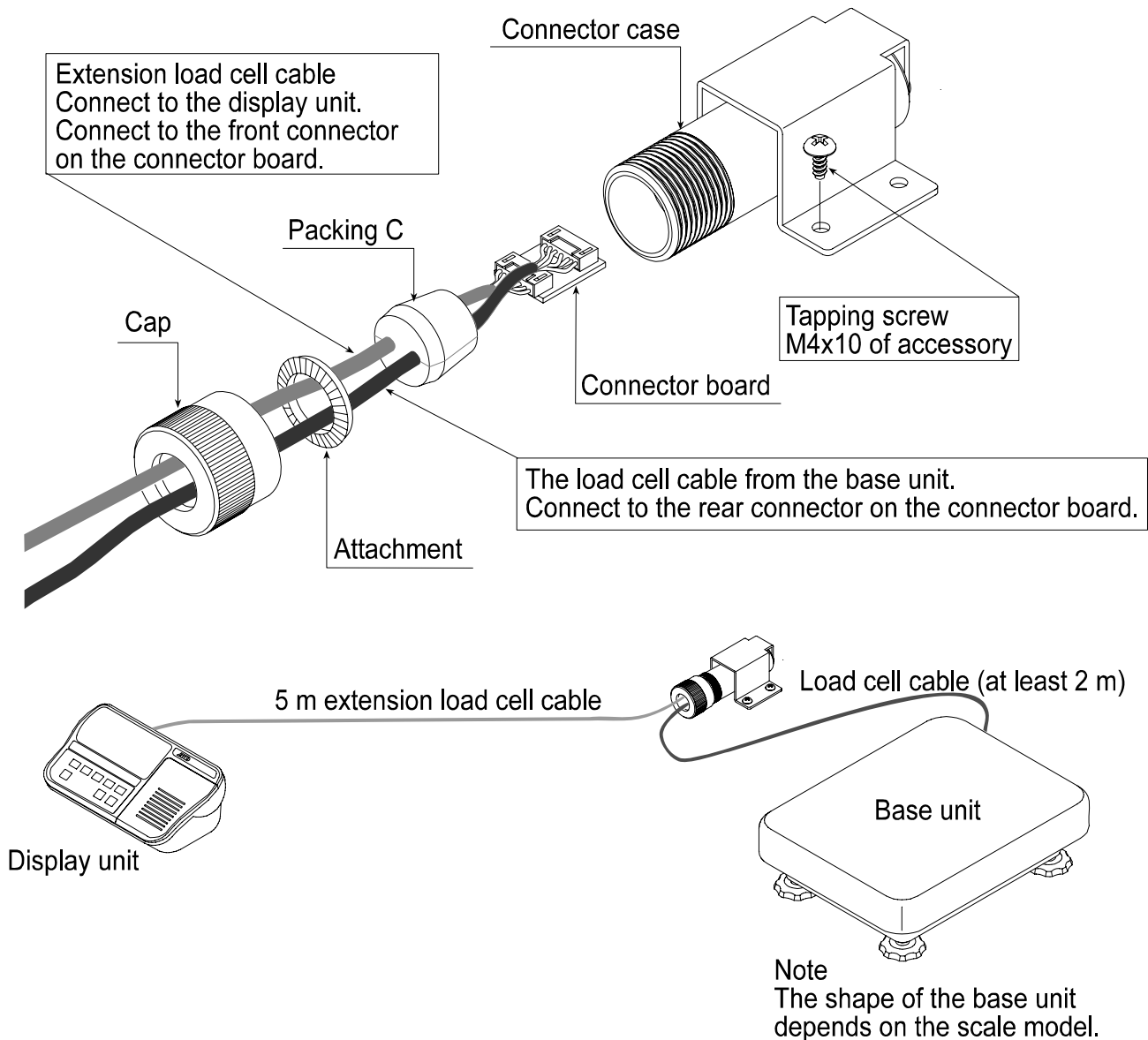

For models with weighing capacity of 300 kg to 1200 kg

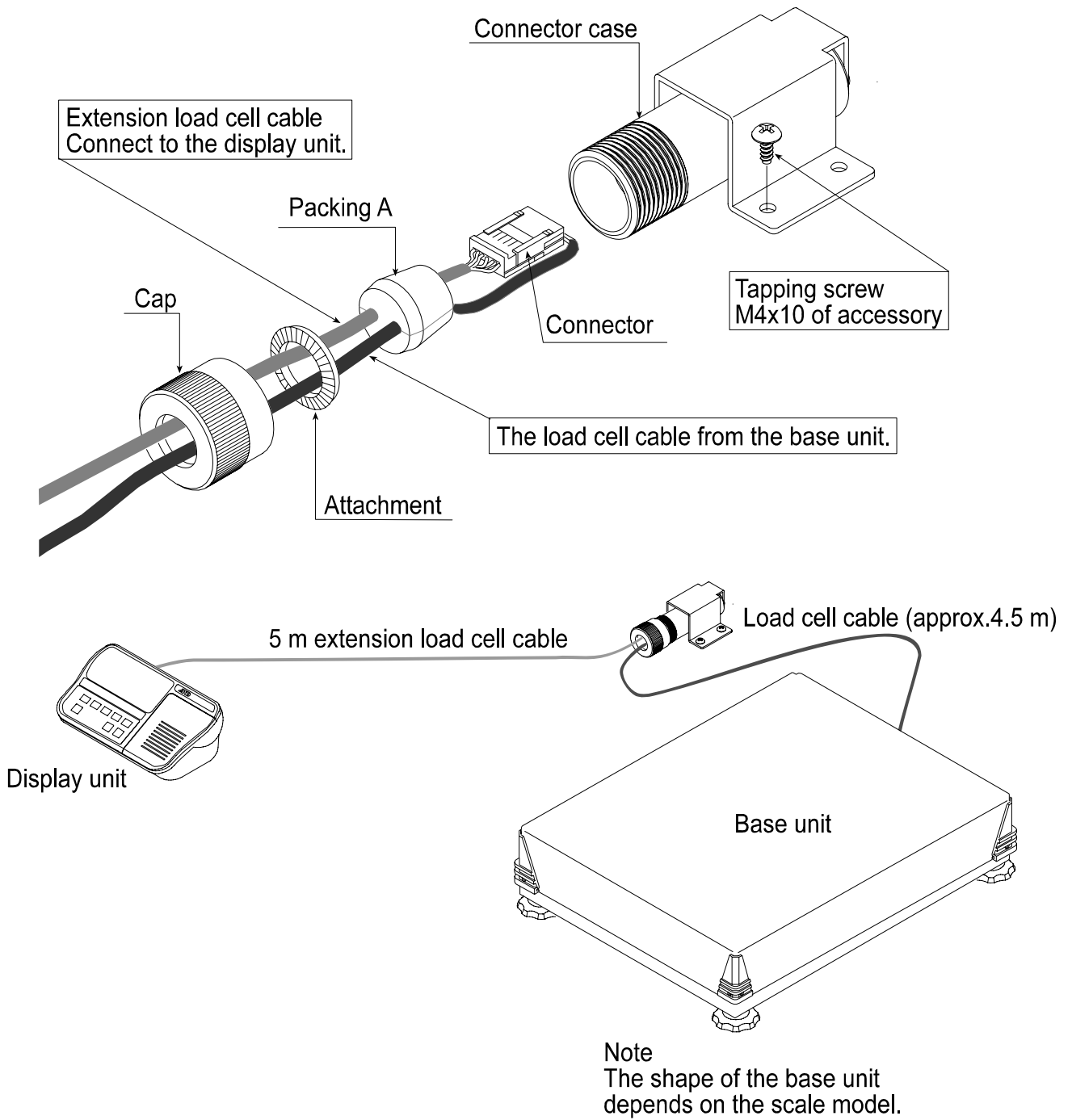

17.2. RS-232C/ Relay Output/ Buzzer (OP-03)

Note When the OP-03 is used, be sure to set the "Address (F11)" to "(00)".

- Replace the standard RS-232C interface with this option. Refer to " RS-232C Serial Interface" for its specification.
- The following optional cables can be used, when you do not use the relay output.
 - AX-KO577A-200 (D-sub 25pin, 2m)
 - AX-KO1786-200 (D-sub 9pin, 2m)

□ Pin connections

Pin No.	Signal name	Direction	Description
1	HI	Output	Relay output of HI
2	RXD	Input	Receive data
3	TXD	Output	Transmit data
4	LO	Output	Relay output of LO
5	SG	-	Signal ground (RS-232C)
6	OK	Output	Relay output of OK
7	DSR	Output	Data set ready
8	COM	-	Relay common terminal

□ Adaptable connector DIN 8pin TCP0586 (of accessory)

□ Circuits

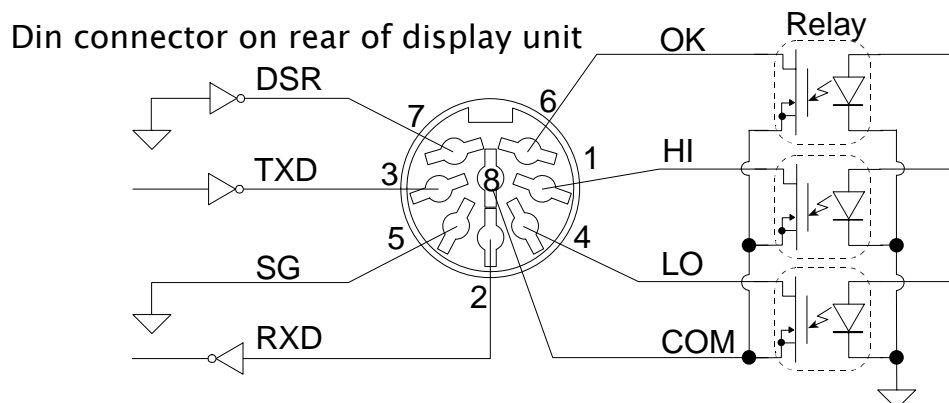

- Relay Solid-state-relay
- | | |
|--------------------|----------|
| Maximum voltage | 50V DC |
| Maximum current | 100mA DC |
| Maximum resistance | 8 Ω |

Installing OP-03

- Step 1 Remove two screws that attach the RS-232C board on rear of the display unit. Remove the RS-232C board.
- Step 2 Switch the connections.
- Step 3 Insert the option board into the display unit and affix with the screws.

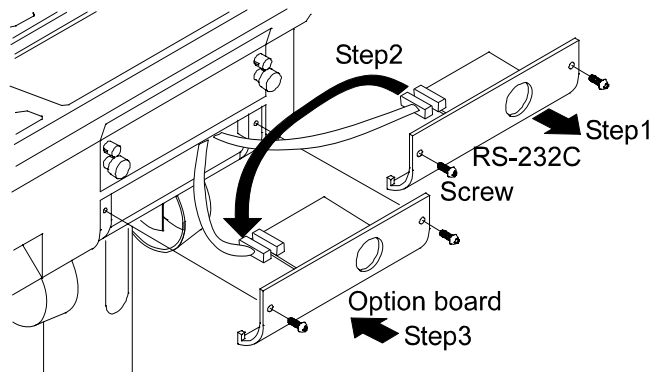

17.3. RS-422/ RS-485 / Relay Output (OP-04)

- Replacing with the standard RS-232C interface, the RS-422/ RS-485 interface can connect up to 16 scales and control them from a computer.
- The RS-422/ RS-485 interface has the following two modes.
 - Stream mode Outputs data continuously.
 - Command mode Controls the scale using commands from a computer.
- To use the RS-422/ RS-485 interface, set the parameters of the "Baud rate (F4)", "Address (F11)", "Output mode (F5)" and " Format (F15)" in the function table.

- Transmission system EIA RS-422/ RS-485
- Transmission Asynchronous, bi-directional, half-duplex
- Data format
 - Baud rate 2400, 4800, 9600 bps
 - Data 7 bits
 - Parity 1 bit, Even
 - Start bit 1 bit
 - Stop bit 1 bit
 - Code ASCII
 - Terminator CR LF (CR: 0Dh, LF: 0Ah)
- Address 01 to 99 Address parameter (F11) of function table.
- Relay
 - Solid-state-relay
 - Maximum voltage 50V DC
 - Maximum current 100mA DC
 - Maximum resistance 8 Ω
- Adaptable connector TM:BLA9 (of accessory)

- Pin connections

Pin No.	Signal name	Direction	Description
1	SDA	Output	RS-422/485 transmission A terminal
2	SDB	Output	RS-422/485 transmission B terminal
3	RDA	Input	RS-422/485 receive A terminal
4	RDB	Input	RS-422/485 receive B terminal
5	TRM	-	120Ω terminator
6	HI	Output	Relay output of HI
7	OK	Output	Relay output of OK
8	LO	Output	Relay output of LO
9	COM	-	Relay common terminal

□ Circuits

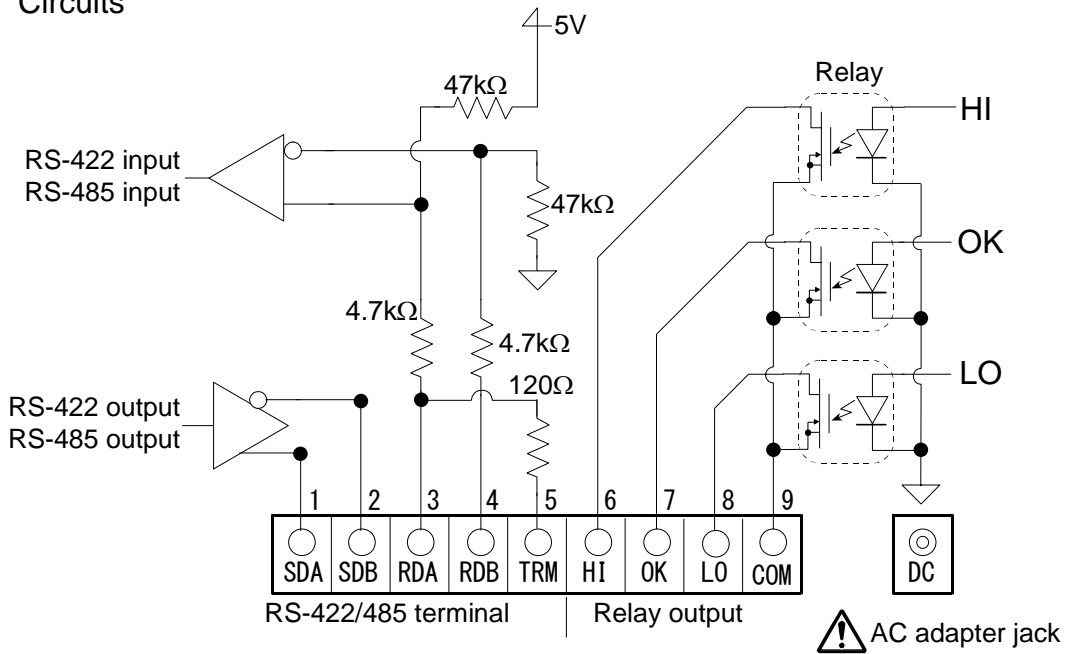

Caution

⚠ Please confirm that the AC adapter type is correct for your local voltage and receptacle type.

Selection switch for the RS-422/ RS-485 interface

Selects either of RS-422 or RS-485 interface using the switch on the board.

Installing OP-04

- Step 1 Remove two screws that attach the RS-232C board on rear of display unit. Remove the RS-232C board.
- Step 2 Switch the connections.
- Step 3 Insert the board into the display unit and affix with the screws.

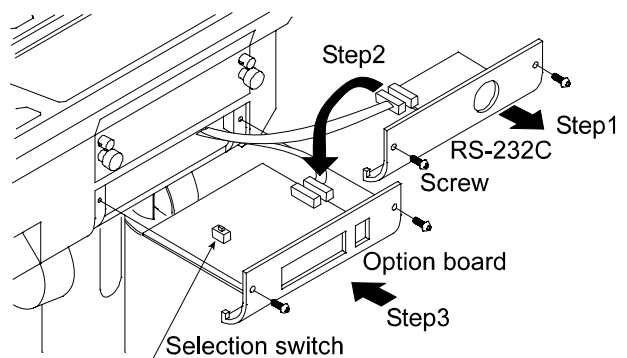

An Example of Connection

The polarities (A, B) of the host computer signal depends on the computer model.

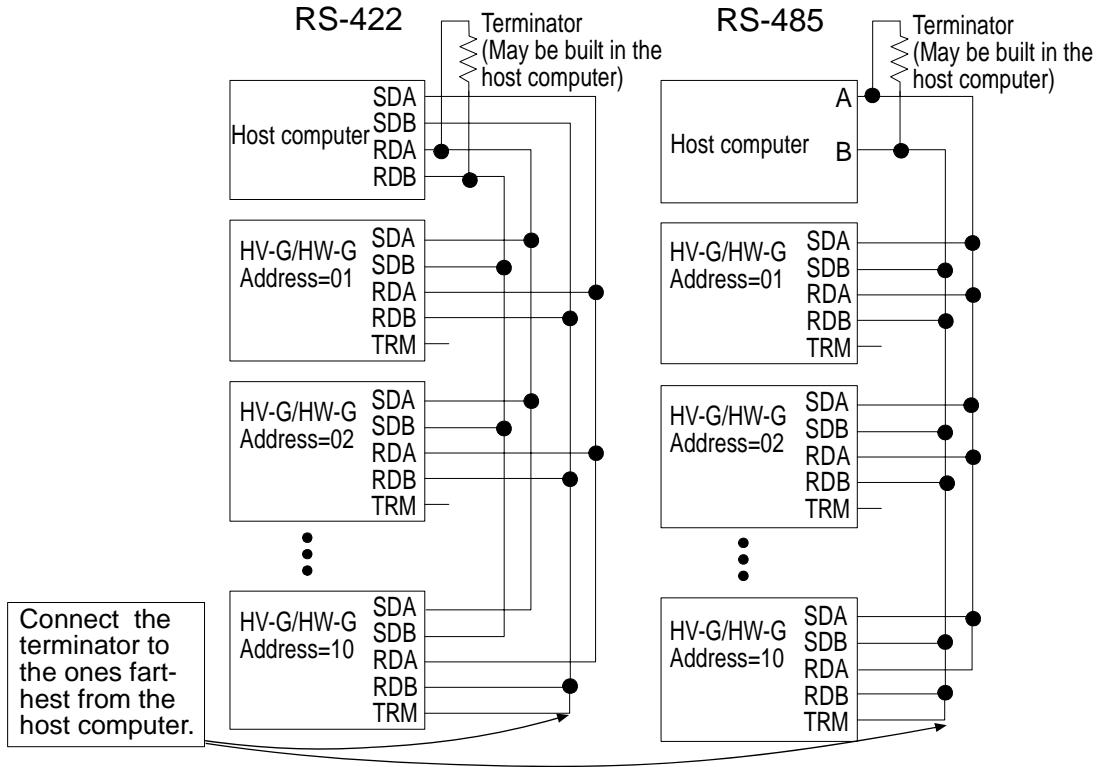

17.3.1. Communication Format

- Commands consist of an address and the same command as for the RS-232C.
- The address of the equipment is inserted in the first part of the command.
- Commands return the same command when the communication format is F 15 3 and there is no transmitting data.
- If the address is 23, the reply is as follows:

Normal response

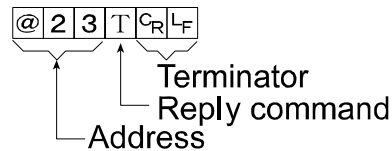

Response of impossible command

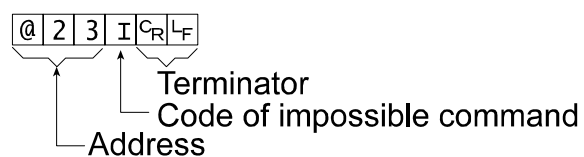

Undefined command response

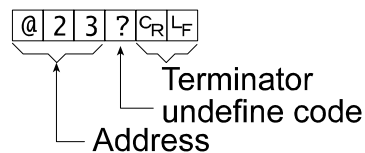

Bit Format

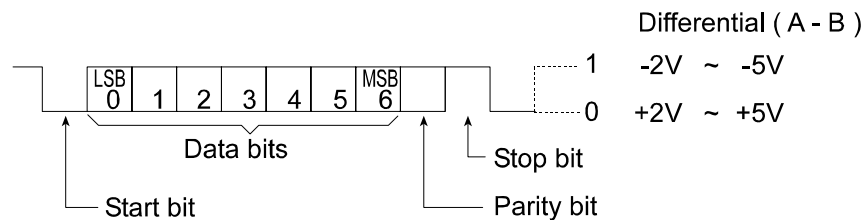

17.3.2. Command List

The following explanation uses "Format 1 (F 15 3)" and assumes that the address is 23.

Data output

The current weighing data is output.

Template

Q

Command

@ 2 3 Q C_R L_F

Reply

@ 2 3 S T , + 0 0 0 1 2 . 4 0 _ k g C_R L_F

Selection of mode and unit

Selects the mode and unit. This is the same as the MODE key.

Template

U

Command

@ 2 3 U C_R L_F

Reply

@ 2 3 U C_R L_F

The scale changes mode and unit.

Zero

The current mass value is set to the zero point.

This is the same as the **ZERO** key.

Template Z
Command @ 2 3 Z C_R L_F
Reply @ 2 3 Z C_R L_F

The mass value becomes zero and zero point mark is displayed.

Tare

With a tare (container) placed, the current mass value is set to zero, and the net is displayed. This is the same as the **TARE** key.

Template T
Command @ 2 3 T C_R L_F
Reply @ 2 3 T C_R L_F

The current mass value becomes zero and the net mark is displayed.

Cancel of tare

The weight value becomes the gross and the net mark is turned off. (The tare value becomes zero.)

Template CT
Command @ 2 3 C T C_R L_F
Reply @ 2 3 C T C_R L_F

Gross is displayed and the net mark is turned off.

Preset tare

The tare value is set and the net is displayed. The net mark is displayed.

The set value is a 5 digit numerical value with a polarity sign and does not contain a decimal point.

Template PT, [parameter]
Command @ 2 3 P T , + 0 0 1 2 0 C_R L_F
Reply @ 2 3 P T , + 0 0 1 2 0 C_R L_F

Net is displayed and the net mark is displayed.

Upper limit value

The upper limit value is stored. The set value is a 5 digit numerical value with a polarity sign and does not contain a decimal point.

Template HI, [parameter]
Command @ 2 3 H I , + 0 3 2 1 0 C_R L_F
Reply @ 2 3 H I , + 0 3 2 1 0 C_R L_F

The upper limit value is stored.

Caution The upper limit value must be greater than the lower limit value.

Lower limit value

The lower limit value is stored. The set value is a 5 digit numerical value with a polarity sign and does not contain a decimal point.

Template LO, [parameter]
Command @ 2 3 L O , - 0 0 4 0 0 C_R L_F
Reply @ 2 3 L O , - 0 0 4 0 0 C_R L_F

The lower limit value is stored.

Caution The lower limit value must be less than the upper limit value.

Accumulation data output

Accumulated data is output.

Template A

Command @ 2 3 A C_R L_F

Reply @ 2 3 A , + 0 0 0 1 2 . 4 0 _ _ k g C_R L_F

Accumulation count output

Number of accumulations is output.

Template N

Command @ 2 3 N C_R L_F

Reply @ 2 3 N , + 0 0 0 0 0 1 4 0 _ _ _ C_R L_F

Reset of accumulation data and accumulation count

Accumulated data and number of accumulations become zero.

Template CA

Command @ 2 3 C A C_R L_F

Reply @ 2 3 C A C_R L_F

Data and number of accumulations become zero.

Final value

The final value is stored. The set value is a 5 digit numerical value with a polarity sign and does not contain a decimal point.

Template S0, [parameter]

Command @ 2 3 S 0 , + 0 2 0 0 0 C_R L_F

Reply @ 2 3 S 0 , + 0 2 0 0 0 C_R L_F

The value is stored.

Preliminary value

The preliminary value is stored. The set value is a 5 digit numerical value with a polarity sign and does not contain a decimal point.

Template S1, [parameter]

Command @ 2 3 S 1 , + 0 0 2 0 0 C_R L_F

Reply @ 2 3 S 1 , + 0 0 2 0 0 C_R L_F

The value is stored.

Zero band

The zero band is stored. The set value is a 5 digit numerical value with a polarity sign and does not contain a decimal point.

Template S2, [parameter]

Command @ 2 3 S 2 , + 0 0 0 5 0 C_R L_F

Reply @ 2 3 S 2 , + 0 0 0 5 0 C_R L_F

The value is stored.



17.4. Built-in Printer for Type V (OP-06)

- To use the printer, set the parameter of the "Print mode (F9)" in the function table.
- To print the date, set the parameter of the "Date (F17)" in the function table.

Caution The date parameter is not updated automatically.

Specification

Type	5x7 dot matrix impact type
Characters	16 characters per line
Width of roll paper	44.5 mm
Accessories	A special roll paper and an ink ribbon

Consumables

Special roll paper	AX-PP156-S	(10 rolls)
Ink ribbon	AX-ERC-05-S	(5 ink ribbons)

Operation and Print Samples

- Press and hold the PRINT key and press the F key. Paper feed is performed.

- Print sample of the print mode F9 1 to F9 4 selected.

```

2.345 kg
2345 Pc
76.98 %

```

- Print sample of the print mode F9 5 selected.

```

99/12/31
001 1.345 kg
002 1.325 kg
003 1.330 kg

```

- Print sample of the accumulation data displayed using the MODE key.

```

99/12/31
N 3 kg
Total 7.810 kg

```

Installing the Printer Paper (Special roll paper)

Step 1 Open the cover.

Step 2 Cut the paper end for easy insertion.

Step 3 Install the paper end and press the **F** and **PRINT** keys at the same time. (Paper Feed)

Step 4 Arrange the ribbon using the dial.

Step 5 Pass the paper end through the cover and close the cover.

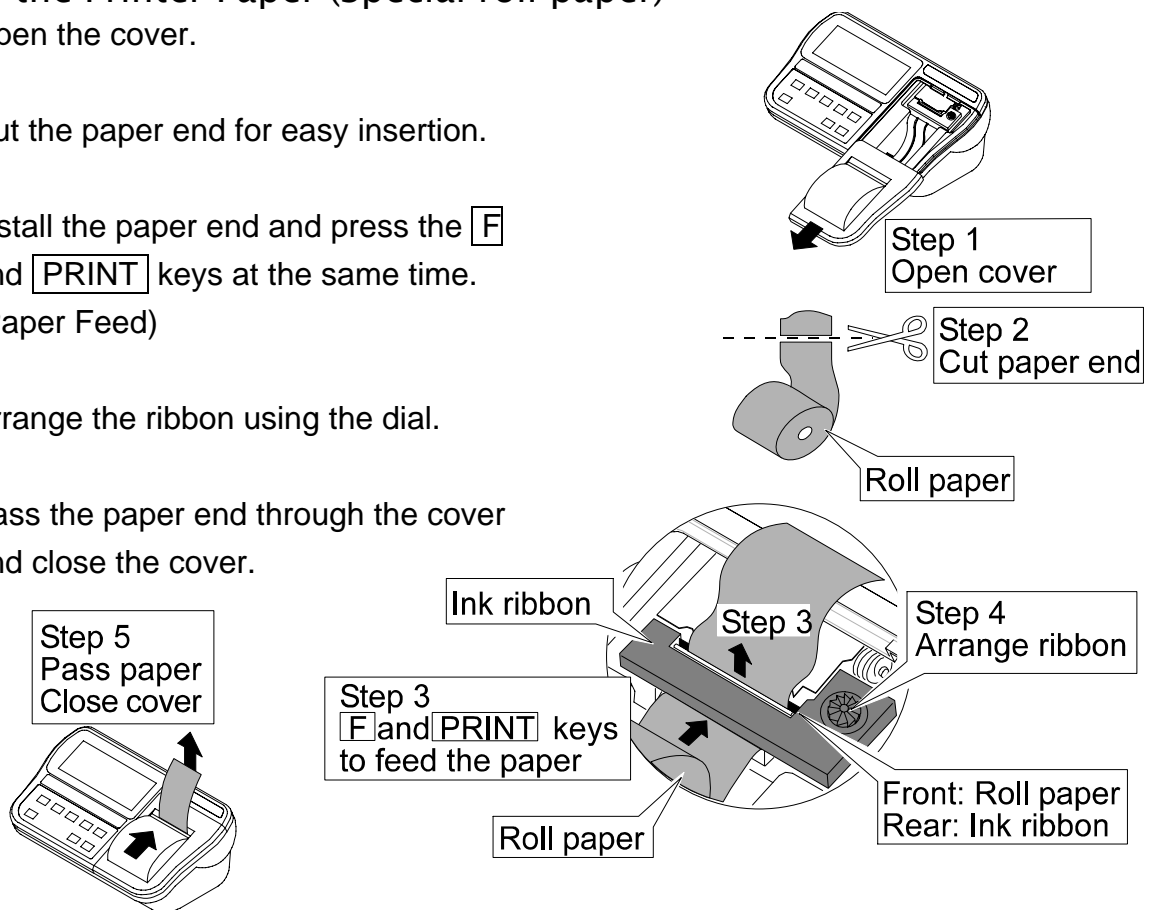

Replacing the New Ink Ribbon

Step 1 Open the cover.

Step 2 Press the left side of the ink ribbon to remove it.

Step 3 Replace with a new ink ribbon.

Step 4 Arrange the ribbon using the dial.

Step 5 Close the cover.

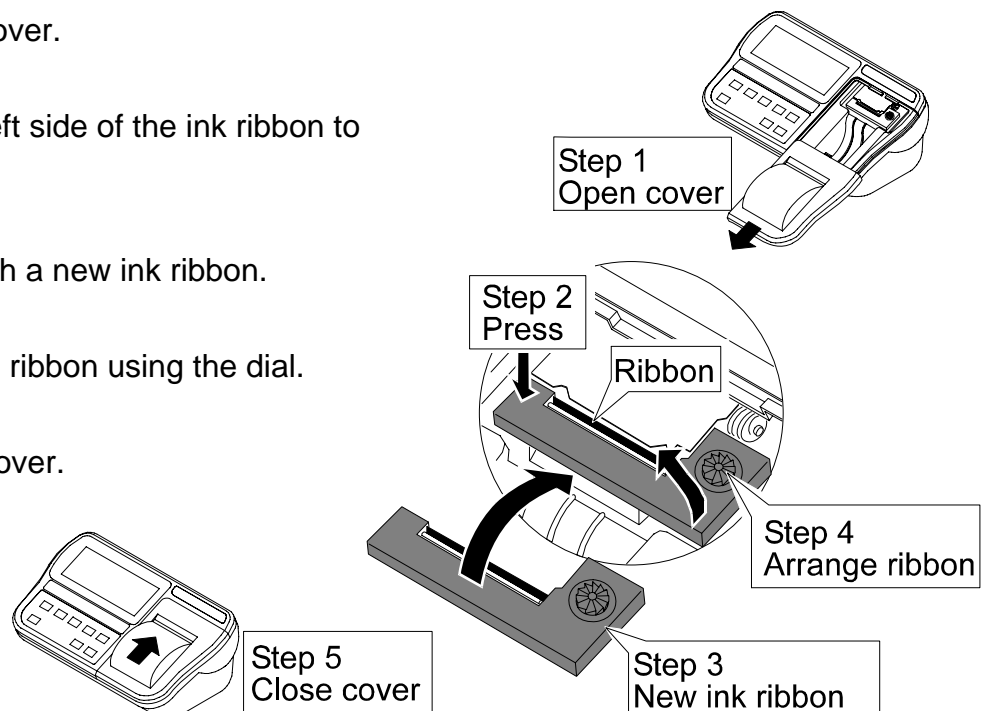



18. Specifications

HV-G Series

Models		HV-15KGL HV-15KGV			HV-60KGL HV-60KGV			HV-200KGL HV-200KGV		
Weighing Capacity	[kg]	3	6	15	15	30	60	60	150	220
Min. weighing (1 digit)	[g]	1	2	5	5	10	20	20	50	100
Weighing Capacity	[lb] #	6	15	30	30	60	150	150	300	500
Min. weighing (1 digit)	[lb] #	0.002	0.005	0.01	0.01	0.02	0.05	0.05	0.1	0.2
Weighing Capacity	[oz] #	96	240	480	480	960	2400	2400	4800	8000
Min. weighing (1 digit)	[oz] #	0.05	0.1	0.2	0.2	0.5	1	1	2	5
Weighing Capacity	[lb_oz] #	30 lb			---					
Min. weighing (1 digit)	[lb_oz] #	0.1 oz			---					
Number of samples in counting mode [pieces]		5 (can be changed to 10, 20, 50, 100)								
Max. count number [pieces]		15,000			12,000			11,000		
Display	HV-GL	7 segment liquid crystal display, Character height 25 mm								
	HV-GV	7 segment fluorescent display, Character height 20 mm								
Repeatability [g]		±1	±2	±5	±5	±10	±20	±20	±50	±100
Linearity [g]		±1	±2	±5	±5	±10	±20	±20	±50	±100
Span drift		20ppm/°C typ. (5°C to 35°C)								
Power rating		230V AC (+10%-15%) 50/60Hz 20VA, Fuse T200mA or 120V AC (+10%-15%) 50/60Hz 20VA, Fuse T315mA								
Power source	HV-GL	AC adapter Please confirm that the AC adapter type is correct for your local voltage and receptacle type. 50Hz/ 60Hz. Battery x 6 pieces R20P, R20PU, LR20, type D or Mono								
	HV-GV	Please confirm that the Main power type is correct for your local voltage and receptacle type.(50Hz/ 60Hz)								
Battery life (HV-GL)		Approximately 600 hours with alkaline battery								
Ambient temperature and humidity		-10°C to 40°C, Less than 85%R.H. (Do not allow condensation)								
Weighing pan size [mm]		250 x 250			330 x 424			390 x 530		
Dimensions [mm] Width x Depth x Height		275 x 474 x 368			330 x 621 x 771			390 x 712 x 773		
Mass of scale [kg]	HV-GL	6			11			17		
	HV-GV	7			12			18		

: If the law in your area permits, you can use these units.

HW-G Series (Weighing Capacity: 10 kg to 200 kg)

Models		HW-10KGL HW-10KGV	HW-60KGL HW-60KGV	HW-100KGL HW-100KGV	HW-200KGL HW-200KGV
Weighing Capacity	[kg]	10	60	100	220
Min. weighing (1 digit)	[g]	1	5	10	20
Weighing Capacity	[lb] #	20	150	200	500
Min. weighing (1 digit)	[lb] #	0.002	0.01	0.02	0.05
Weighing Capacity	[oz] #	320	2400	3200	8000
Min. weighing (1 digit)	[oz] #	0.05	0.2	0.5	1
Weighing Capacity	[lb_oz] #	20 lb	---		
Min. weighing (1 digit)	[lb_oz] #	0.1 oz			
Number of samples in counting mode [pieces]		5 (can be changed to 10, 20, 50, 100)			
Max. count number [pieces]		10,000	12,000	10,000	11,000
Display	HW-GL	7 segment liquid crystal display, Character height 25 mm			
	HW-GV	7 segment fluorescent display, Character height 20 mm			
Repeatability [g]		±2	±10	±20	±40
Linearity [g]		±2	±10	±20	±40
Span drift		20ppm/°C typ. (5°C to 35°C)			
Power rating		230V AC (+10%-15%) 50/60Hz 20VA, Fuse T200mA or 120V AC (+10%-15%) 50/60Hz 20VA, Fuse T315mA			
Power source	HW-GL	AC adapter Please confirm that the AC adapter type is correct for your local voltage and receptacle type. 50Hz/ 60Hz. Battery x 6 pieces R20P, R20PU, LR20, type D or Mono			
	HW-GV	Please confirm that the Main power type is correct for your local voltage and receptacle type.(50Hz/ 60Hz)			
Battery life (HW-GL)		Approximately 600 hours with alkaline battery			
Ambient temperature and humidity		-10°C to 40°C, Less than 85%R.H. (Do not allow condensation)			
Weighing pan size [mm]		250 x 250	330 x 424	390 x 530	390 x 530
Dimensions [mm] Width x Depth x Height		275 x 474 x 368	330 x 621 x 771	390 x 712 x 773	390 x 712 x 773
Mass of scale [kg]	HW-GL	6	11	17	17
	HW-GV	7	12	18	18

: If the law in your area permits, you can use these units.

HW-G Series (Weighing Capacity: 300 kg to 1200 kg)

Models		HW-300KGL4 HW-300KGV4	HW-600KGL4 HW-600KGV4	HW-600KGL3 HW-600KGV3	HW-1200KGL3 HW-1200KGV3
Weighing Capacity [kg]		300	600	600	1200
Min. weighing (1 digit) [g]		50	100	100	200
Weighing Capacity [lb] #		600	1500	1500	3000
Min. weighing (1 digit) [lb] #		0.1	0.2	0.2	0.5
Number of samples in counting mode [pieces]		5 (can be changed to 10, 20, 50, 100)			
Max. count number [pieces]		6,000	6,000	6,000	6,000
Display	HW-GL	7 segment liquid crystal display, Character height 25 mm			
	HW-GV	7 segment fluorescent display, Character height 20 mm			
Repeatability [g]		± 100	± 200	± 200	± 400
Linearity [g]		± 100	± 200	± 200	± 400
Span drift		20ppm/°C typ. (5°C to 35°C)			
Power rating		230V AC (+10%-15%) 50/60Hz 20VA, Fuse T200mA or 120V AC (+10%-15%) 50/60Hz 20VA, Fuse T315mA			
Power source	HW-GL	AC adapter Please confirm that the AC adapter type is correct for your local voltage and receptacle type. 50Hz/ 60Hz. Battery x 6 pieces R20P, R20PU, LR20, type D or Mono			
	HW-GV	Please confirm that the Main power type is correct for your local voltage and receptacle type.(50Hz/ 60Hz)			
Battery life (HW-GL)		Approximately 350 hours with alkaline battery		Approximately 250 hours with alkaline dry battery	
Ambient temperature and humidity		-10°C to 40°C, Less than 85%R.H. (Do not allow condensation)			
Weighing pan size [mm]		600 x 700		1,000 x 1,000	
Dimensions [mm] Width x Depth x Height		615 x 935 x 938		1,000 x 1,210 x 937	
Mass of scale [kg]	HW-GL	45		108	
	HW-GV	46		109	

: If the law in your area permits, you can use these units.

Dimensions

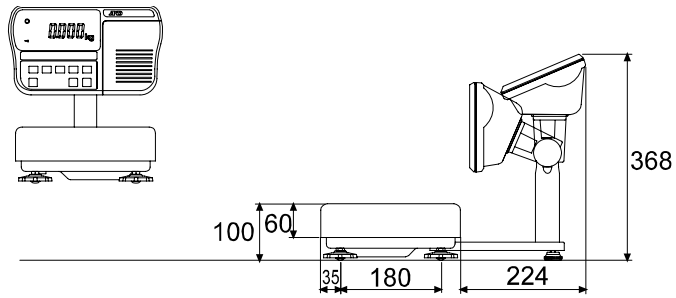

Models
 HV-15KGL HV-15KGV
 HW-10KGL HW-10KGV

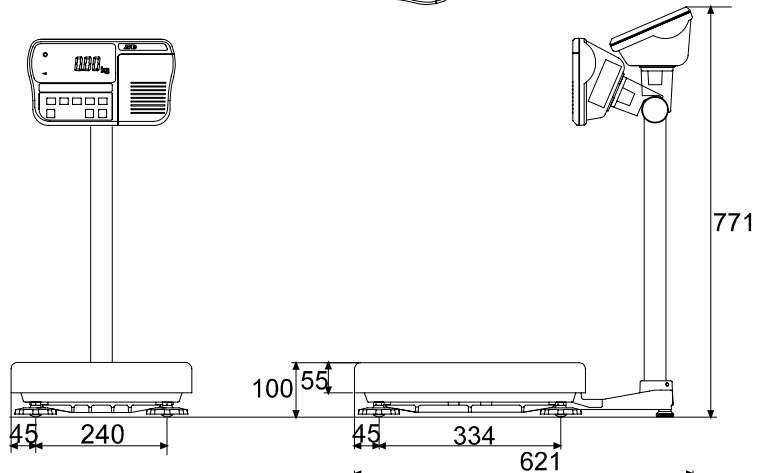
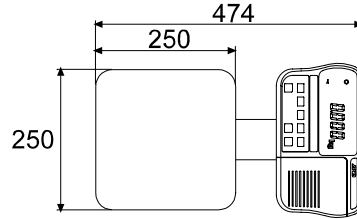

Models
 HV-60KGL HV-60KGV
 HW-60KGL HW-60KGV

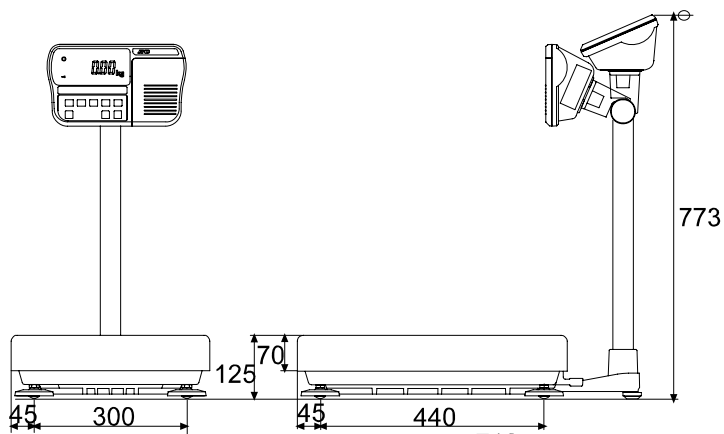
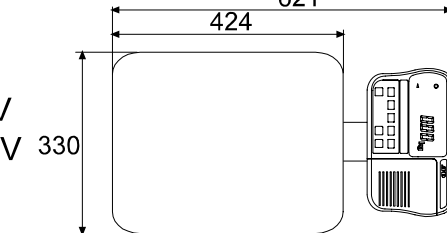

Models
 HV-200KGL HV-200KGV
 HW-100KGL HW-100KGV
 HW-200KGL HW-200KGV

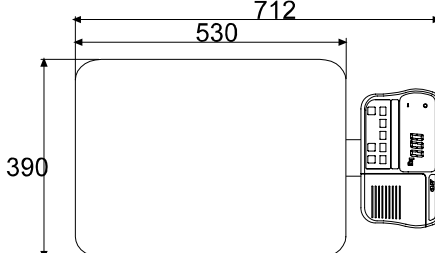

Unit: mm



Models
 HW-300KGL4 HW-600KGL4
 HW-300KGV4 HW-600KGV4

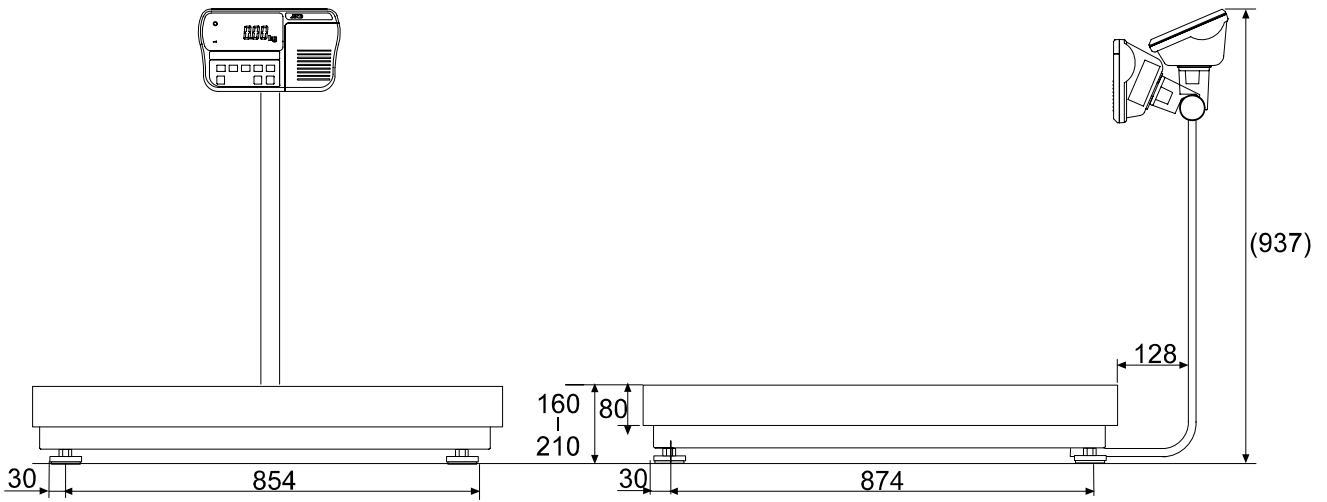
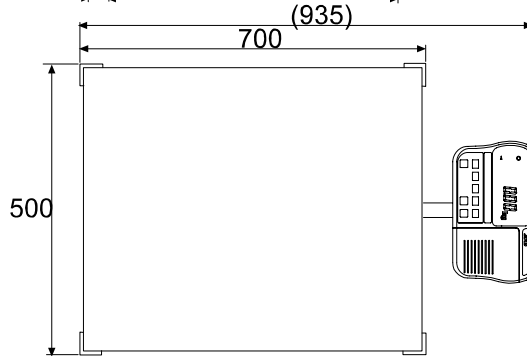

Models
 HW-600KGL3 HW-1200KGL3
 HW-600KGV3 HW-1200KGV3

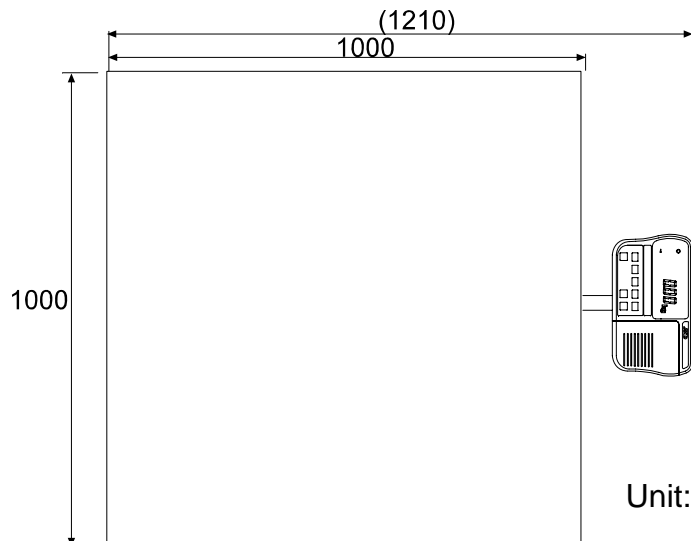

Unit: mm



19. Maintenance

- Refer to "4. Precautions" for use.
- Refer to "6.1. Display and Symbols " and corresponding mode for displayed error code.
- Refer to "14. Calibration (Adjusting the Scale)" for precision weighing.
- Periodically check the accuracy of the weighing. Calibrate the scale, if it has been moved to another location or the environment has changed.



19.1. Check Points Before Calling Maintenance Service

In this situation	Confirm these items
Nothing is displayed. Scale does not turn on.	<ul style="list-style-type: none"> □ Is the AC adapter properly connected? □ Is the AC adapter of the correct voltage ? □ Are the batteries dead ? □ Is the battery direction correct ?
The scale does not display zero upon power-on.	<ul style="list-style-type: none"> □ Check around the weighing pan. □ Is there anything on the pan? □ Perform zero point calibration.
----- is displayed and does not proceed.	<ul style="list-style-type: none"> □ The weight value is unstable due to drift, vibration or other. A breeze or vibration may be affecting the measurement. Check around the weighing pan. □ Check the connection of load cell cable. □ No zero display when the display is turned on. Remove anything that is on the pan. □ Perform zero point calibration.
CARL E is displayed	<ul style="list-style-type: none"> □ Calibration error that means "Too heavy".
-CARL E is displayed	<ul style="list-style-type: none"> □ Calibration error that means "Too light".
E is displayed	<ul style="list-style-type: none"> □ Weighing error that means "Overload".
-E is displayed	<ul style="list-style-type: none"> □ Weighing error that means "Underload".
Fixed display	<ul style="list-style-type: none"> □ Do you use the hold function? □ Turn off the scale and turn it on.

19.1.1. Repair

Do not disassemble or assemble the scale without an authorized service engineer. It may cause an electrical shock or damage to the scale. In this case, repair is not covered under warranty. Contact your local A&D dealer if your scale needs service or repair.

MEMO
