

CONTINUATION

Dear User,

Description in the manual is based on the newest products. Owing to improvement or other changes, contents of manual may differ from practical situation. Our company will reserve the right of recension at any moment. Please kindly forgive not to notify the revised places one by one.

The copyright of this manual belongs to Wenzhou Sundoo Instruments Co., Ltd. Any companies or individuals have no rights to copy or plagiarize part or whole contents of the manual without permission of our company.

制造商：温州山度仪器有限公司

MANUFACTURER: WENZHOU SUNDOO INSTRUMENTS CO.,LTD

地址：浙江省温州市龙湾区西台工业区西工西路5号

Add: No.5, Xigongxi Road, Xitai Industrial Zone, Wenzhou China

Zip: 325011

Tel: +86 577 88609905 Fax: +86 577 88390155

Http://www.sundoo.com E-mail: export@sundoo.com

Ver:5.01 Con:20161015

SH Series
User Manual

数显式推拉力计
DIGITAL FORCE GAUGE

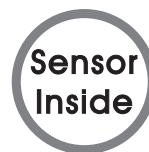

传感器内置



温州山度仪器有限公司
WENZHOU SUNDOO INSTRUMENTS CO., LTD

- 3、Don't disassemble, repair and remodel the gauge by yourself.
- 4、Please contact our company if there is any problem or fault.

Packing List

Number	Parts Name	Quantity
1	Main body	1
2	Power adaptor	1
3	Test attachments	5
4	Prolong stick	1
5	M3×8 screws	4+1
6	CD	1
7	Manual	1
8	Factory inspection report	1
9	Qualification card	1

Thanks for your patronage to purchase SH Series Digital Force Gauge. With compact size and high accuracy, this force gauge can be used to measure tension/compression force. It is easy to operate and handy to carry out. The force gauge can display the test direction. It has the blue background light. The gauge can set the upper and lower limit deviation value to judge the measured results. It has installed the red/green indicator lamp and buzzer, which can alarm automatically with sound and light. The gauge can store 10 test values and calculate the average of the stored test values automatically. It can convert three units (N, kgf, lbf) automatically. The data can roll over on the screen. Peak-holding function, peak automatic discharge function and the discharge time can be set freely. The gauge can turn off automatically if it has no operation, and the shutdown time can be set freely. This gauge has RS-232C port output. It has the curve test function if it connects to PC. It can print 10 groups of stored test data and judge the max, min, average, qualified or unqualified values if it connects to the printer. If it connects to test stand, it can make the test stand stop moving when it reaches to the preset stop value. Before using this instrument, please read the manual carefully so that you can make full use of this instrument and get accurate load value.

CONTENT

- Parameter2
- Dimension3
- Test Stand4
- Caution and Warning5
- Function6
- Main Characteristic6
- Work Environment6
- Parts Appellation and Function.....7
- Test Preparation11
- Test12
- Memory Function/Stored Value/Min Captured Value14
- Serial Port Output and Print.....15
- Rechargeable Battery Group.....18
- Maintenance.....18
- Packing list.....19

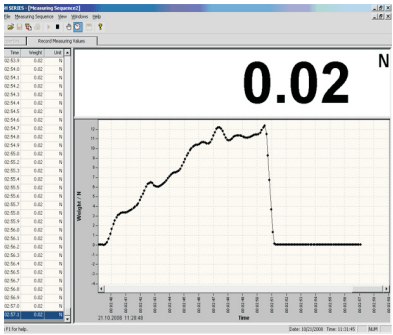

Picture 15

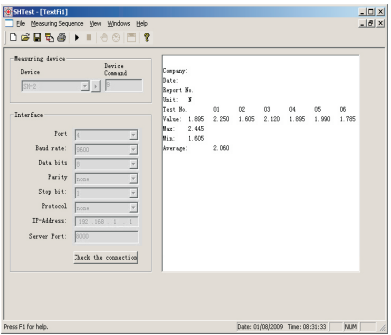

Picture 16

3. When serial port communication mode is "Stand", please connect force gauge to computer via RS232 cable. By setting the stop value of force gauge, when the test value reaches to preset stop value, the test stand will stop moving automatically.

Rechargeable Battery Group

During using the gauge, if the mark “” flicker, it means that the battery is very low and need to be charged. Please use matched “DC 12V/400mA” charger. With smart charging technology, it will stop charging automatically after charging fully. Practically protect the battery durability.

Note:

- 1、Frequent and long-playing charging will shorten battery life.
- 2、Please charge when the battery only has a grid or less a grid power to avoid not to charge fully because of very low power.
- 3、Charge the battery fully at least once three months.

Maintenance

- 1、Please clean the gauge with soft cloth. Put dry cloth in the water with detergent and clean the gauge after drying it. Don't use volatile chemicals, such as volatile oil, thinner, alcohol.
- 2、Handle carefully when using and carrying.

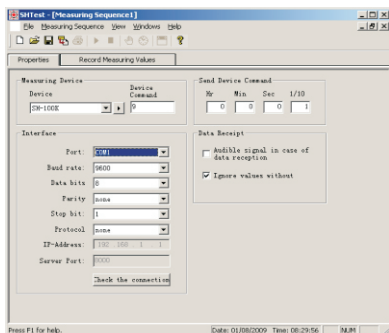

Picture 13

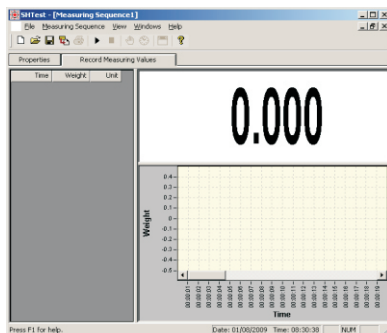

Picture 14

- G. After setting the parameters, please click "Record Measuring values" option, and switch to curve display interface.
- H. After clicking start button "▶", then click "TIMER" (🕒) to collect test data curve (See Picture 14).
- I. After finishing test, please click stop button "■" to stop testing (See Picture 15).
- J. Click save button to save the data.
- K. If you choose the Text File, it means that you can import the stored data of the force gauge. Please choose the matched model and corresponding serial port, then click the start button "▶" to open the serial port and press "PRINT" on the force gauge to import the stored data to the computer (See Picture 16).

Icon instruction

- "📄": The collection data is imported into EXCEL file;
- "▶": Open serial port to start test;
- "■": Close serial port to stop test;
- "🖨️": Collect current value manually;
- "🕒": Collect the data continuously and regularly.

Parameter

Model	SH-500	SH-200	SH-100	SH-50	SH-20	SH-10	SH-5	SH-2							
Capacity	500N	200N	100N	50N	20N	10N	5N	2N							
Resolution	0.1N	0.1N	0.05N	0.01N	0.01N	0.005N	0.001N	0.001N							
Testing range	10%~100%FS														
Accuracy	Within ±0.5%														
Unit	N,kgf,lbf														
Sensor conformation	Sensor inside														
Power	Adaptor: DC 12V/300mA Battery inside: Ni-MH 8.4V 1200mAh														
Use time	Continuous use for about hours														
Standby time	About 3 Month														
Battery life	≥300 times														

Dimension

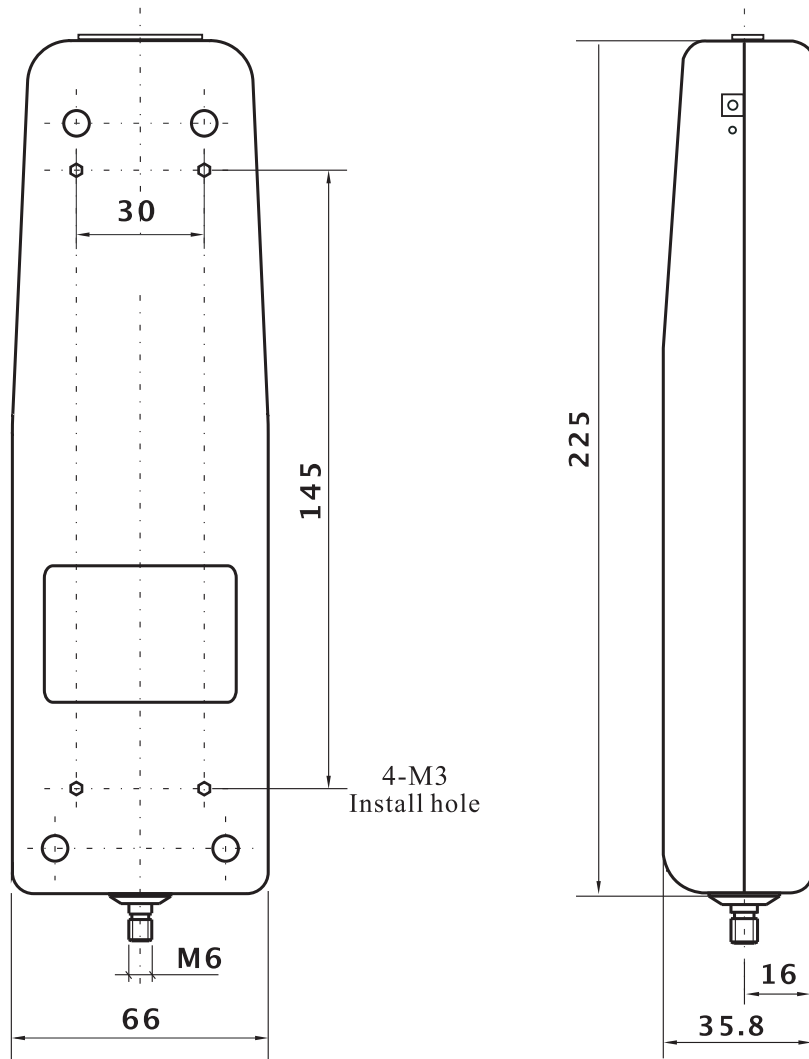

Picture 1

- Operating system: Windows XP (32bit).
- (3) Specific operation
- Connect force gauge with computer via RS232 cable.
 - Turn on the gauge power, make it in working status, then set the serial ports mode as PC state (See Item 5 on Page 13).
 - Put CD into computer drive and open software route: CD-ROM/English/Measuring software/SH/SH Test/SH Test.exe.
 - Click "New" in the "File" option (See Picture 11).

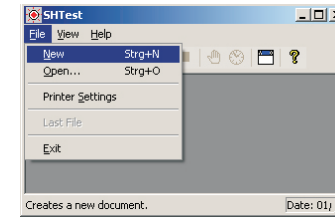

Picture 11

- There are two modes to choose in new dialog box: Measuring Sequence and Test File (See Picture 12).

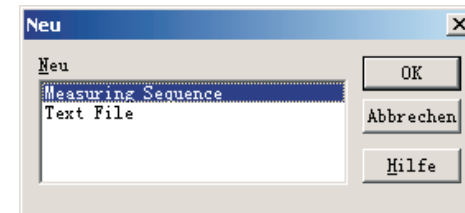

Picture 12

- After choosing "Measuring Sequence", please choose corresponding model and serial port, and set the time of capturing the signal of force value in Send Device Command. 1/10 means 0.1 second (See Picture 13: When Hr is 0, Min is 0, Sec is 0, 1/10 is 1, then the capturing time is 0.1 second).

If you want to view the average of all stored data, please press "MEMO" and it will display AVERAGE on LCD screen. Small digital box displays the average of all stored data. Pressing "MEMO" can back to memory status.

Serial Port Output and Print

This gauge is RS-232C level output, which can be connected with printer, computer or appropriate test stand. The matching micro printer must support RS-232C electrical level.

1. When serial port output mode is Print, press "PRINT" button, and the LCD screen flickers and displays "Print", printing out 10 groups of stored data and analysis report (See Picture 10).

Illustration of RS-232 Port

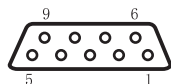

Needle	Signal	Illustration
2	TxD	Output signal of scm
3	RxD	Receipt signal of scm
5	GND	Earth
6	+2V	Over upper limit
7	+2V	Lower than lower limit
8	+2V	Ok is the eligible

Picture 9

Print Sample

Title	SH-500 TEST REPORT:-----
Data for memo	DATE:-----
No	NO:-----
Unit of value	UNIT: N
Upper limit	HIDT: 420.5
Lower limit	LODT: 222.1
Peak capture line	LE. SET: 10.0
	-01 150.2 -
	-02 198.3 -
	-03 450.5 +
	-04 85.5 -
	-05 256.8 OK
	-06 270.8 OK
	-07 266.6 OK
	-08 400.2 OK
	-09 368.9 OK
	-10 286.5 OK
The test value or data	
+ is over upper limit,	
- is the lower than	
lower limit, Ok is the	
eligible	
Max value	MAX: 450.5
Min. Value	MIN: 85.5
Average value	AVERAGE: 273.4

Picture 10

2. When serial port output mode is PC, you can view force curve by software or input 10 groups of stored data to computer by connecting to computer.

The required configuration and specific operation are as follow :

(1) Hardware environment

A. CPU: Celeron 1G or above.

B. Memory: 256MB or above.

C. Hard disk available capacity: 300MB or above.

D. Drive: CD-ROM or DVD-ROM.

(2) Software environment

Test Stand



SLJ-B



SPJ-B

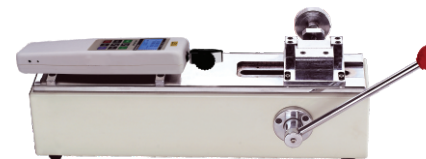

SPH



SJX-500H



SJX-5KV

Note: The above test stands and clamps need to purchase additionally.

Picture 2

Caution and Warning



Wrong operation may destroy this gauge or lead to grave accident. This manual teaches you how to avoid accidents and use this instrument. Please read this manual carefully before using it. Please keep it properly after using it. If you want to test shock load, please choose twice as large as the max load of testing shock load. The effective measurement range of this instrument is 10%~100%of full range.



1. Please wear protective mask or gloves to protect yourself from scattering pieces while testing.

2. Don't use the damaged or warped clamps/grips. The damaged or warped clamps/grips may fall from this instrument or be fractured to hurt yourself. Great care should be taken.
3. Don't use it with overload. If it appear "ERROR" on screen, it means that the gauge already exceed sensor capacity, please reduce the load immediately.
4. Usage of overload, shock load of overload and the load besides the directions of push and pull will damage sensor.
5. Do not press the button with pointed tools(like photo A).
6. This gauge is used for tension or compression test (like photo B).Don't force on the test bar's bent or tight direction(like photo C and D).

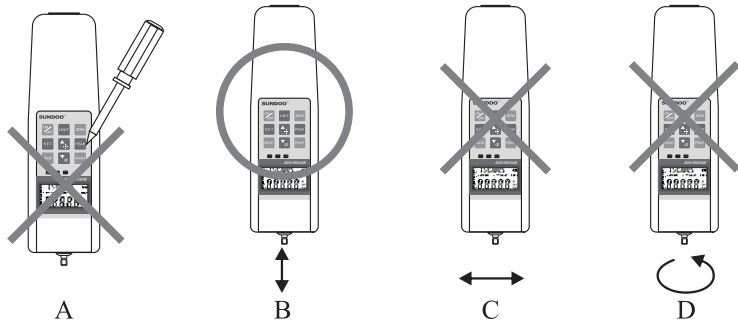

7. When turning on the gauge, please don't apply more than 5% of the reted load.
8. Do not use the gauge near water, oil or other liquids. Please keep it in a

the gauge and the measured sample in a line, otherwise the result will be error.

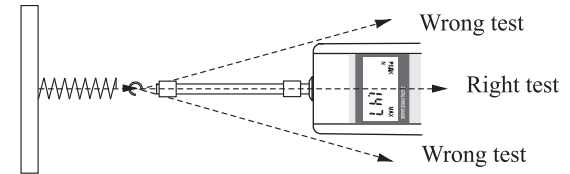

Picture 7

Please close the power after finishing testing, remove the load and test head slowly, then put the gauge and parts in the instrument kit after cleaning them for next use.

Memory Function/Stored Value/Min Captured Value

When using memory function, please choose appropriate min captured stored value "F₀" according to the magnitude of force. During testing, no matter the direction of force, if test value is larger than min captured value,the memory function will start and memorize the max value of this test. If test value is less than min captured value, it will finish a test (See Picture8).

The max value "F_{P1}" will be saved, and the left memory location of LCD screen displays "√", then "▶" indication will move up one location automatically, waiting next memory test. If min captured value is larger than test value, the memory function won't work.

The instrument can store 10 test values. When testing for the eleventh time, the first previous stored value will be replaced. Pressing "▲*" "▼x" can choose stored location. Small digital box will display stored value of this location.

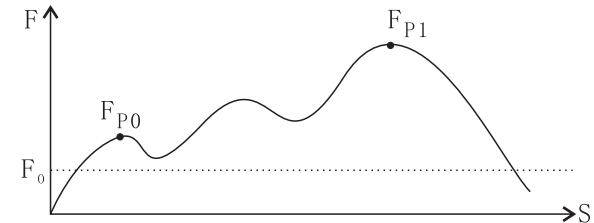

Picture 8

4. Select suitable unit

Three units (N, lbf and kgf) can be switched circularly before testing or during testing.

5. Setting upper and lower limit deviation values, min captured value, stop value of test stand, automatic power-off time, peak-holding automatic discharge time, and serial port output mode:

Press "SET" for the first time, the LCD screen will display "HIDT", and the digital box displays current upper limit value. Pressing "▲▼" can change current value.

Press "SET" for the second time, the LCD screen will display "LODT", and the digital box displays current lower limit value. Pressing "▲▼" can change current value.

Press "SET" for the third time, the LCD screen will display "LE.SET", and the digital box displays min captured value of the stored values.

Pressing "▲▼" can change current value.

Press "SET" for the fourth time, the LCD screen will display "Stop", and the digital box displays current stop value of test stand. Pressing "▲▼" can change current value.

Press "SET" for the fifth time, the LCD screen will display "P.OFF", and the digital box displays automatic power-off time. Pressing "▲▼" can change current value.

Press "SET" for the sixth time, the LCD screen will display "A.PE", and the digital box displays peak holding automatic-discharge time. Pressing "▲▼" can change current value.

Press "SET" for the seventh time, the LCD screen will display "RS232", and the digital box displays Print, PC or Stand. Pressing "▲▼" can change current status

Press "SET" for the eighth time, the instrument will save all changed settings and back to working condition.

Note: During setting, pressing "ZERO" can save setting and back to working condition.

When the gauge is connected with PC for curve tracing points test, the serial communication mode should be set as PC mode, otherwise it will be not normal for connecting with PC.

6. Testing

Please fix the gauge on the suitable test stand for testing. Please keep

shady, dry and stable place.

9. Please use matching charger to charge, otherwise it will cause electrical fault, even fire.

10. Please use it after inserting charger into socket completely. Loose plug may cause short-circuit, which may lead to electric shock or fire.

11. Do not use power exceeding the capacity of charger, otherwise electric shock or fire may happen.

12. Please don't pull out or insert power adapter with wet hands, otherwise it may lead to electric shock.

Function

SH Series Digital Force Gauge is a new generation universal push pull instrument. With compact size, light weight, taking easily, multifunction and high resolution, it can be used for various tests, such as tension/compression test, insertion/withdraw test and destructive test. It can be combined with various test stands and clamps to be a small testing machine with different use.

Main Characteristic

1. High accuracy, high resolution.
2. Free setting and judgment of upper and lower limit deviation value, red/green indication lamps and buzzer can alarm automatically with sound and light.
3. Test direction display.
4. Turn on/off the blue background light.
5. 10 groups of test data can be stored and calculate the average of the stored data automatically.
6. Convert three units (N, kgf, lbf) automatically.
7. The data displayed on LCD screen can be rolled over.
8. Peak-holding function, peak automatic discharge function and discharge time can be set freely.
9. It can turn off automatically if it has no operation, and the shutdown time can be set freely.
10. RS-232C output. Connecting to computer can realize curve test function; connecting to printer can print 10 groups of stored test data and judge the max, min, average, qualified or unqualified value; connecting to special test stand can make the test stand stop moving when reaching to the preset stop value.

Work environment

- 1、 Work temperature: $20^{\circ}\text{C} \pm 10^{\circ}\text{C}$;
- 2、 Relative humidity: 35%RH~65%RH;
- 3、 No shock and corrosivity materials around.

Parts Appellation and Function

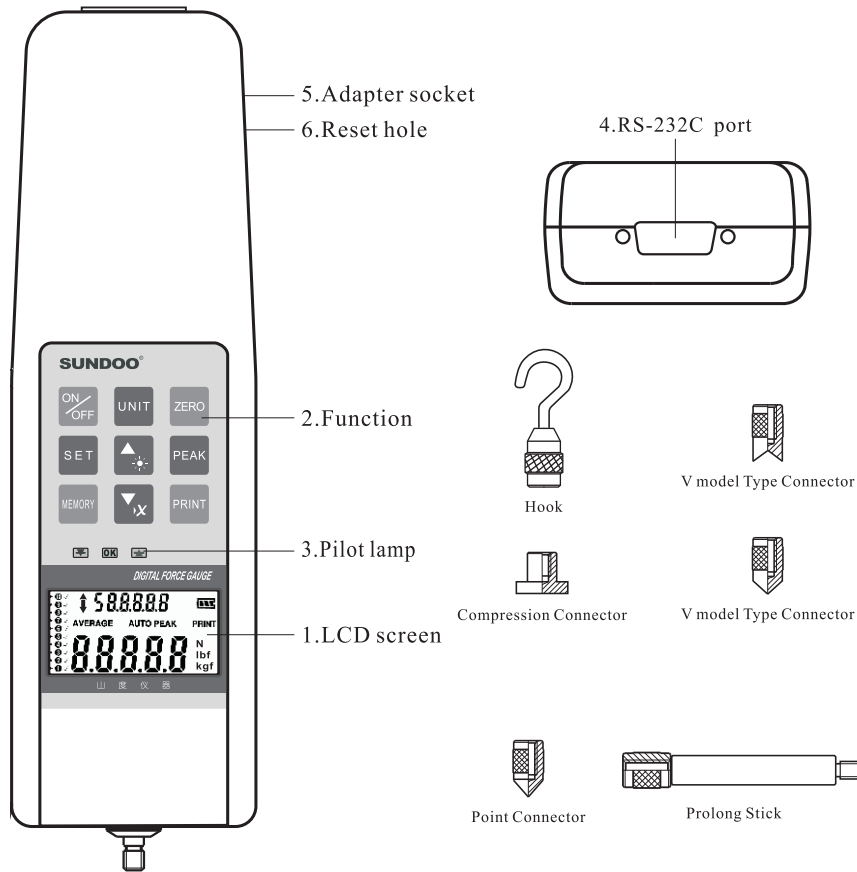

Picture 3

2. Install test head

During testing, applicable test head accessories or clamps/grips could be chosen to install on the test bar. Please don't twist test head with too much force, otherwise the sensor will be destroyed. The size of test head is as Picture 6.

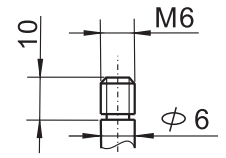

Picture 6

Test

1. Turn on the power

ON: Under shutdown status, press " ON/OFF ". After power on, the instrument firstly enters into self-checking program, and the screen will display "SUNDOO" and the instrument model, then the instrument enters into normal working status. If there is a clamp installed on the sensor and the clamp load is lower than 5% of the instrument's max load, the gauge will clean to zero automatically when power on. If clamp load exceeds 5% of the instrument's max load, it may lead to wrong display. At this time, please choose lighter clamp.

OFF: Under power on status, if the instrument isn't used, it will shut down automatically according to the preset shutdown time, and you can also press " ON/OFF " to shut down the power.

2. Clean to zero

After power on, if the reading is steady, pressing " ZERO " can clean to zero (Attention: the range of cleaning to zero is $\pm 5\%$ of rated load). Under peak holding mode, pressing " ZERO " can clean peak value. Under setting status, pressing " ZERO " can save the setting value and back to working state.

3. Choose test mode



Real-time tracking of load/peak-holding/peak-holding automatic discharge could be chosen. After power on, the default state is real-time tracking of load, and there is no "PEAK" on screen; press " PEAK ", the screen will display "PEAK" and enter into peak-holding status, and the reading of instrument is max value which test bar can bear during testing. Under peak holding status, pressing " ZERO " can clean to zero on the screen. Press " PEAK " again, the LCD screen will display "AUTO PEAK" and enter into peak-holding automatic discharge status, and the instrument will clean to zero automatically according to preset time, waiting to the next peak value. Each time you press " PEAK ", three testing modes can be switched.

3. Indicator lamps

"" indicator lamp of upper limit alarm value.

"OK" normal/stop value indicator lamp.

"" indicator lamp of lower limit alarm value.

Under PC or Print mode(See RS-232 setting on Page 13), if test value is in the range of upper and lower limit deviation, normal value indicator lamp "OK" will light, meaning that it is eligible; if test value exceeds upper limit value, the indicator lamp of upper limit "" will light, and the buzzer alarms, meaning that it is not eligible; If the test value is less than lower limit value, the indicator lamp of lower limit "" will light, and the buzzer alarms, meaning that it is also not eligible. This can inform users that the test result isn't in the range.

Under Stand mode(See the Item 3 on Page 18), when test value reaches to preset stop value, the test stand will stop automatically, and the indicator lamp "OK" lights; if stop value isn't in the range of upper and lower limit, the indicator lamp "OK" and the upper and lower limit indicator lamps "" will light at the same time when the test stand stops.

4. Communication interface

RS-232C port output is used for connecting printer, PC or special test stand.

5. Power adapter socket



Applied with power adapter DC 12V, 300mA.

6. Reset hole

Be used for restart the instrument when it is disturbed strongly.

Test Preparation



1. Check the power supply

Turn on the instrument and check the battery, if it shows "" on LCD screen, it means lack of electricity, and the battery group needs to be charged. The method is as follow: Please put the matched power adapter into the charging port, and plug into AC 220V/50HZ. If "" flickers, it means that it is being charged. The instrument can automatically calculate the charging time, and it can stop charging when it is full. It can be charged no matter power on or off, and it can be used to test even though it is being charged.

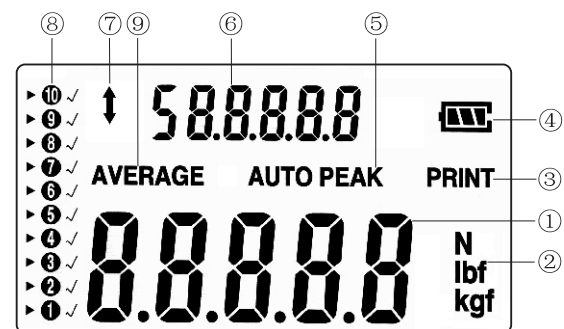
1. The LCD screen window



Picture 4

- ① Test value reading of push pull force gauge. Under setting status, it displays set value.
- ② Test units of push pull force gauge
Three different units of measurement: N, lbf, kgf can realize automatic conversion.
- ③ Printing of all stored data.
- ④ Electric quantity indication of battery
When the power is low, it displays "" or flickers, meaning that the battery needs to be charged. When the battery is being charged, the power indication "" flickers.
- ⑤ Peak value indication
When it displays "PEAK" on LCD screen, it is max test value in locked status; when it displays "AUTO PEAK", the peak is in automatic discharge status.
- ⑥ Stored test value, average of the stored data or the symbols of indication function at the set state.
- ⑦ The symbol of push pull force direction
Push force test displays "↑" and pull force test displays "↓", which are the same as actual test directions.
- ⑧ Store test value
"12345678910" ten locations, each location can store one test value;
"▶" shows that it is current stored reading location;
"✓" shows that the location has already stored test value.

⑨ Average indication symbol of stored test data.

2. The function of buttons



Picture 5



ON/OFF Button



Zero Button

Be used for cleaning to zero, cleaning peak value and saving set value.



Unit Button

- Unit conversion key of push pull force test;
- Pressing unit key for 3 seconds can roll over the data direction on LCD screen.



Peak Button

Converting three states: peak-holding, peak-holding automatic discharge and real-time tracking of the load. Real-time tracking of the load is default status after power on.



Print Button

Be used for printing current data (See Item 1 on Page 15).



Memory Button

Be used for saving test value and calculating the average of stored data . Calculating the average automatically is default status after power on. Under the state of automatically calculating the average of stored data, pressing "MEMORY" can make "AVERAGE" disappear and enter into the state of storing the test value. Press "MEMORY" again, the LCD screen

shows "AVERAGE" and enters into the state of automatically calculating the average of stored data.



Set Button

- Setting upper and lower limit automatic alarm values.
- Setting stored min captured value.
- Setting the stop value of the test stand.
- Setting automatic shutdown time (free setting from 1~60minutes, 0 is not automatic shutdown).
- Setting peak-holding automatic discharge time (free setting from 1~10 seconds).
- Setting serial port output mode.



Plus Button/Background Light Switch

- Under storing test value status , press "▲", and "▶" symbol will forward one location. If there is no "√" symbol beside the location, it means that the location is blank , and test datum will be stored into the location. If there is "√" symbol beside the location, it means that test value has been stored into the location, and the new test value will replace previous stored value.
- Under setting status, press"▲" and the set value will increase. If you press it all the time, the data will increase continuously.
- Under average indication status, pressing "▲" can turn on/off LCD background light.



Reduce /Delete Button

- Under storing test value status , press "▼", and "▶" symbol will backward one location. If there is no "√" symbol beside the location, it means that the location is blank , and test datum will be stored into the location. If there is "√" symbol beside the location, it means that test value has been stored into the location, and the new test value will replace previous stored value.
- Under setting status, press"▼" and the set value will decrease. If you press it all the time, the data will decrease continuously.
- Under average indication status, pressing"▼"can delete all stored data.