



DFS Series User's Manual (5N-1000N Capacity)

REV 3.8

Table of Contents

Table of Contents.....	2
Introduction.....	3
Before Use.....	3
Operation Overview.....	4
Powering the DFS.....	5
Using the DFS.....	6
Fitting Accessories.....	6
Mounting to a Test Stand.....	6
Powering up.....	7
Basic Functions.....	7
Main Menu.....	11
AUTO-OFF.....	11
PASS-FAIL.....	12
MEMORY.....	14
CALIBRATION.....	15
DIAGNOSTIC.....	15
SELECT OUTPUT.....	16
ABOUT.....	16
Measurement Practice.....	17
DFS Specifications.....	18
Conversion Factor.....	19

Introduction

Thank you for choosing the Nextech DFS series instrument. With correct use and regular re-calibration it can give many years of accurate and reliable service.

The DFS can measure tensile and compressive forces accurately, while being simple to use by the operator. It may be used handheld or mounted to a fixture or test stand.

Software and accessories are included to make your force gauge even more versatile.

Before Use

Warning: Please read the entire manual carefully before using the Nextech gauge. Make certain that any person using or having access to the gauge reads and understands the entire manual beforehand. Improper use of the gauge could cause damage and/or void its warranty.

Never attempt to remove the rear cover nor repair the gauge yourself.

***Do not overload the load sensor.** Whether the DFS is powered ON or Off, overloading the sensor will cause irreparable damage. When powered ON, forces greater than 120% of full-capacity will produce an audible beep and an OL symbol will blink on the display until the load is released and the RESET key is pressed.

Operation Overview

The Nextech DFS has been designed to give the user easy access to its most commonly used features.

Listed below is a brief overview of some of these features, and their corresponding key-presses located on the front panel. If desired, this page can be printed out as a "Quick Reference Guide". However, as stated previously the entire manual should be read in its entirety before using the DFS. More detailed information on these features can be found throughout this manual.





Button/Key	Effect
POWER	1. Powering On and OFF the DFS instrument. 2. Invert the display. (Pressing MENU + POWER simultaneously)
ZERO	Sets the starting point, taring-out the weight of attachments.*
RESET	Reverts to the starting point that was set with the ZERO function.
UNIT	Cycles through "Units" of measurement. (Grams, ounces, newtons, etc.)
MODE	Cycles through the types of applied load force. (Push, Pull, and Tracking)
ENTER	1. Records a measurement to the internal memory. 2. Selects the highlighted option from within a menu.
PRINT	Prints the memory's contents to the serial port.
MENU / ESC	1. Enters the Main Menu system to allow configuration of the DFS gauge. 2. A means of escaping the menu system one level per button press.

* "Taring" deducts the weight of an attached accessory from the gross weight in order to display only the weight that we are interested in measuring.

Powering the first time

The DFS is supplied with a set of 4 Nickel Metal Hydride AAA rechargeable batteries. For safety reasons during transportation the batteries are shipped discharged. To obtain maximum battery life we recommend that you charge them with the charger/adaptor supplied for at least 14-16 hours when you first receive the instrument. When subsequent recharges are necessary, it is recommended that the DFS is charged for 8 hours.

Battery Indicator

	Battery level is at full capacity
	Battery level is at 75% of capacity
	Battery level is at 50% of capacity
	Battery level is at 25% of capacity
	Battery level is less than 5% of capacity

If battery level is 0%, the “battery empty” message will be displayed and the gauge will power down automatically.

When plug in the charger, after few minutes the battery level will show battery capacity full. Actual remaining battery capacity can be view only when charger is not connected.

*Important: Only use the adaptor/charger supplied.

Using the DFS

Fitting Accessories

Couple DFS fitting directly to the load cell stem. The threads are M6 and have capacities up to 1000 N.

Ensure that anything coupled to the gauge is screwed finger-tight only. Excessive torque can damage the load cell and is not covered by warranty.

Mounting to a Fixture or Test Stand

To secure the DFS to a suitable mounting plate, use the two M5 threaded holes. The distance between the holes is 2.5 inches. Alternatively, four 3mm thread holes on the rear of the gauge can be used to mount the gauge also.

An appropriate mounting plate must be used to ensure that the fixture does not directly contact the force gauge case. An optional versatile mounting plate is available to couple the force gauge to many brands of test stands.

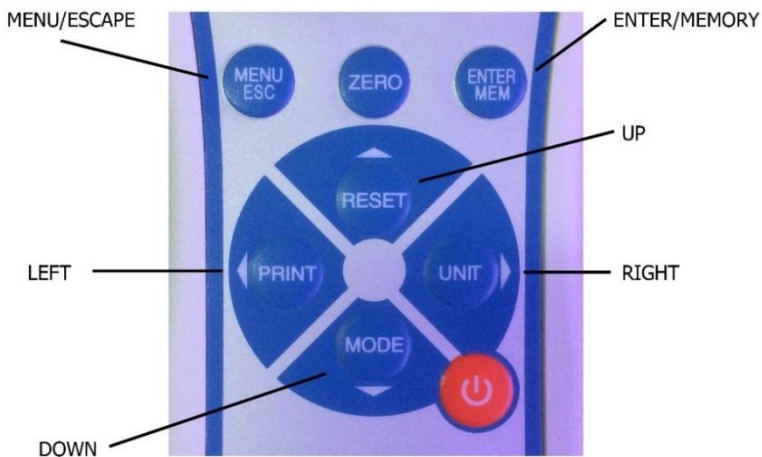

Figure 1 DFS control panel

Powering up

The control panel has eight keys, as show in figure 1.

To power up the gauge, press the ON/OFF key located at the lower right of the keypad. A short self-test will begin, during which, the display will show the maximum capacity in Newtons.

After completing the self-test, providing no load has been applied to the instrument, the display will show all zeroes. This is because the gauge re-zeroes itself during the self-test routine.



**If a force is applied via the load cell probe (threaded stem at bottom of the DFS), the reading on display will register the applied force.*

**Forces may not show zero if the DFS is moved, or weight/force applied during the self-test routine. Once it is properly mounted in either vertical or horizontal position and zeroed, the reading will be stable.*

To power-down the gauge, press the ON/OFF key.

**All of the current DFS settings are saved when the gauge is turned off and the gauge will function in the same mode when powered-up again.*

Basic Functions

Tensile forces are displayed on the DFS and recognized by the symbol ,
Compressive forces are displayed on the DFS and recognized by the symbol 

Display of Tension/Compression

For tension testing the Load Indicator Bar registers right to left.

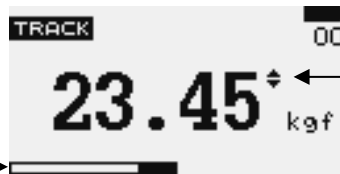

Notice the Tension symbol  following the force reading.



Figure 2 Tension and compression displays

The “Load Indicator Bar” alerts the operator to how much load has been applied to the load sensor. (Note that this bar indicates the tared weight and does not reflect any accessories that have been “Zeroed” out.)

Zeroing the gauge During the operation of the gauge it is often necessary to zero the display – e.g. when you wish to tare out the weight of a grip, so it does not become part of the measured reading. Or when you change the position of the gauge from horizontal to vertical and vice-versa. Press and release the ZERO key.

Changing the unit of measurement You can choose from the following units of measure depending on the capacity of your gauge: milliNewtons, kiloNewtons, Newtons, gram-force, kilogram-force, ounce-force or pound-force.

To cycle through the available units-of-measure, press the UNITS key. Each successive key press will select the next available unit of measurement until the gauge returns to its original setting. The DFS automatically converts the displayed readings DFS as new units of measure are selected.

**Note: Available units-of-measure are limited by model type. See table on page 18 to find out which units are available on each model.*

Changing the mode of measurement You can choose from the following types of measurement: Track, Peak-Tension, and Peak-Compression,

To cycle through the available mode, press the MODE key. Each successive key press will select the next available mode until the gauge returns to its original setting.

Track mode Press MODE key until the **TRACK** appears on the display. The display will now indicate forces applied in both directions as they are applied to the load sensor in real-time. See Figure 3a

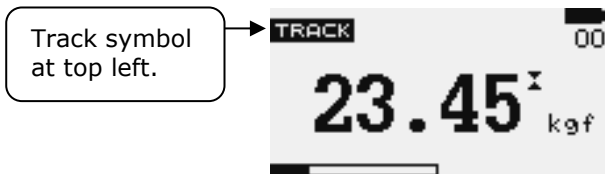

Figure 3a Track

Peak-Tension mode Press the MODE key until the **PEAK ↕** appears on the display. The display will now show the maximum tensile force that has been applied to the sensor. See Figure 3b (Again, do not exceed the gross maximum capacity of the DFS model that you are using.)

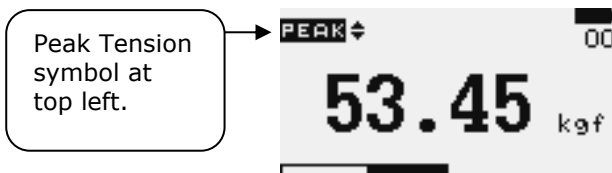

Figure 3b Peak Tension

Peak-Compression mode Press the MODES key until **PEAK ⊥** appears on the display. The display will now show the maximum compressive force that has been applied to the sensor. See Figure 3c

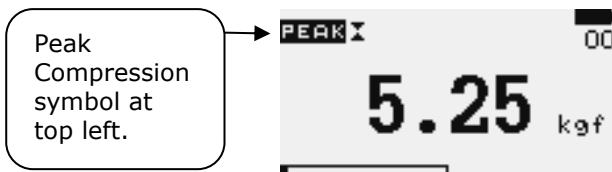

Figure 3c Peak Compression

Resetting the gauge Press the RESET key to clear the current reading and prepare the DFS for the next test.

Backlit Display When you press any key or apply forces to the load sensor greater than 0.5 % of full scale, the backlight will active for 60 seconds.

Invert Display The display may be inverted or “reversed”, so that the operator can read it more comfortably. Press and hold the MENU key while powering up the DFS to invert the display. This feature is remembered after powering down. Perform the same steps again to restore the display to the opposite direction

Saving readings to memory Any reading can be saved anytime by pressing the MEM/ENTER key. A total of 500 readings can be stored to the unit’s internal memory.

Computer Control of Force Gauge A computer can control the force gauge by sending commands through either USB or RS232 port.

Command	Action
“m”	Cycle modes of measurement.
“u”	Cycle units of measurement.
“z”	Zero the gauge.
“r”	Reset to previously set “Zero”.

Output signal The displayed reading may be transmitted to a PC by pressing the PRINT key or sending a request command from a PC to the gauge through either the USB or RS232 port.

Command	Action
“l”	Send live reading value from unit.
“p”	Send peak tension value from unit.
“c”	Send peak compression value from unit.
“x” or pressing PRINT key	Send live reading value from unit, if current mode is track mode. Send peak tension value from unit, if current mode is peak tension mode. Send peak compression value from unit, if current mode is peak compression mode.
“d”	Send memory
“!”	Send information of gauge (model, capacity, serial number, firmware revision, original offset, current offset, overload count).

Main Menu

Press MENU/ESC key to access the main menu. To move between the options listed on the main menu page, press UP and DOWN arrow keys to move the cursor. Press ENTER to select the sub-menus, activate features and enter values. Within sub-menus UP, DOWN, LEFT and RIGHT arrow keys will also change numerical values. Press ESC to return to the main menu page.

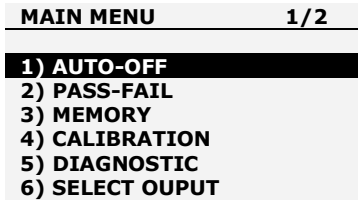

Figure 4 Main Menu

AUTO-OFF If desired, the Auto-Off function can be enabled to conserve battery power. "AO" will appear on the main display when this feature has been activated. The following steps can be used to enable or disable this feature.

1. Press the MENU key, notice that the display now shows Main Menu 1/2 (indicating page 1 of 2) in the navigation bar at the top of the screen.
2. Use UP and DOWN to move the cursor to highlight *AUTO-OFF*.
3. Press the ENTER key. Notice the Auto-Off Menu appears in the navigation bar.
4. From this menu, one of the available Auto-Off time periods can be selected and enabled or this function can be set to OFF.
5. Press the ESC key to return to the Main Menu page.

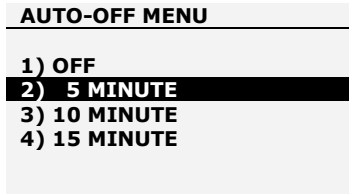

Figure 5 Auto-Off Menu

PASS-FAIL The Pass-Fail feature can be used to define an acceptable range of applied force.

This feature is activated by navigating to the PASS-FAIL Menu.

1. Press the MENU Key to access the Main Menu.
2. Use UP and DOWN to move the cursor to highlight PASS-FAIL.
3. Press the ENTER key to access the PASS-FAIL menu.
4. In this screen the LEFT ARROW key will toggle the cursor between the Upper and Lower values. (Notice that the selected value is underlined)
5. The RIGHT ARROW key will cycle through the units of measure.
6. Press the UP and DOWN keys to change these values incrementally, or press and hold to scroll the values.
7. When you are satisfied with each of the settings, pressing ENTER will save the values, enable the PASS-FAIL function and return you to the Main Menu.

*When the PASS-FAIL feature is active the PF symbol will appear on the main display. While using this feature, an applied load force that is outside of the set range (higher or lower), will display the FAIL message. If the applied load is within this range, the display will show the PASS message.

PASS FAIL MENU		
UPPER =	<u>2.5</u>	N
LOWER =	1.0	N
Press 'Zero' key to Clear both value.		

Figure 6 Pass-Fail Menu

**The Pass-Fail feature will automatically be disabled if you set LOWER and UPPER = 0 N.*

**The LOWER value must be less than the UPPER.*

Example:

For this example we'll assume that a lower threshold has been set to 2 lbf and the upper threshold has been set to 5 lbf:

If we were to apply a load force of say 1.5 lbf, then the yellow LED will signal to us that the applied load has fallen below our test range settings, resulting in a failure.

If we were to apply a load force of 6 lbf then the red LED will signal to us that the applied load is greater than our test range settings, also resulting in a failure.

If we were to apply a load of any force between our two range values, for example 4 lbf, then the green LED will signal that the load has successfully fallen within our upper and lower limits, resulting in a PASS.

Example LOWER LEVEL = 0 lbf, UPPER LEVEL = 5 lbf.

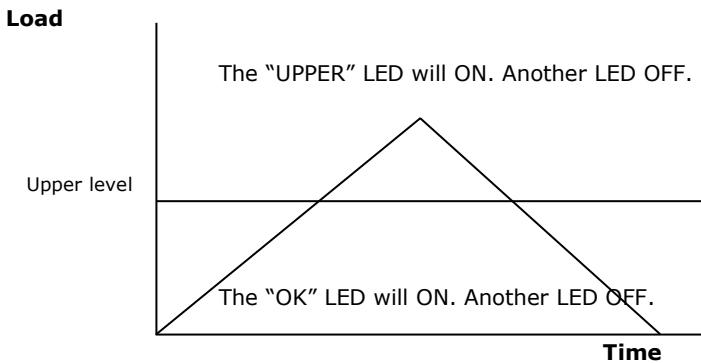

Figure 6a

Example LOWER LEVEL = 2 lbf, UPPER LEVEL = 0 lbf.

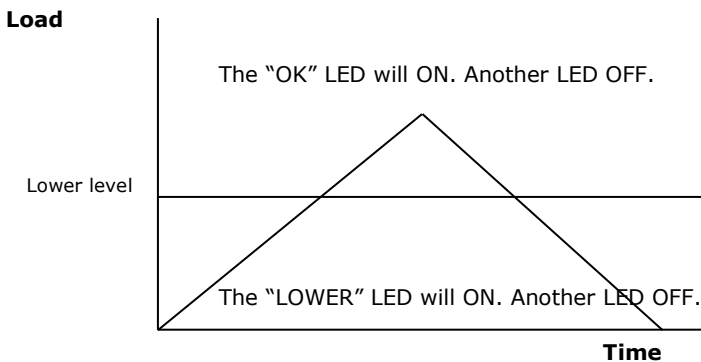

Figure 6b

Example LOWER LEVEL = 2 lbf, UPPER LEVEL = 5 lbf.

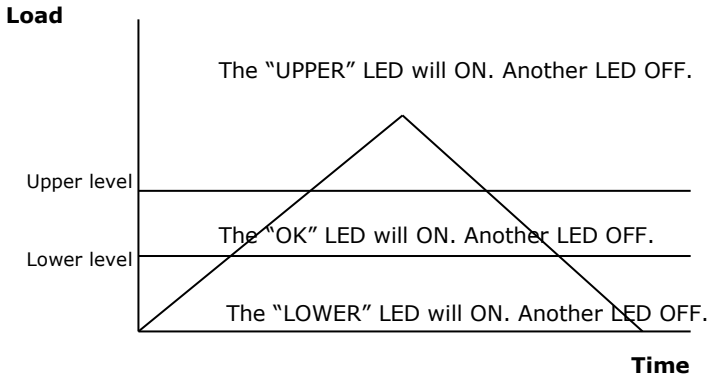

Figure 6c

MEMORY This function is used to view, delete and print saved records.

To access the *MEMORY* menu,

1. Press the MENU key to access the Main Menu.
2. Press UP and DOWN to highlight *MEMORY*.
3. Press the ENTER key to access the Memory Menu. (See figure 7a)
4. Press the UP or DOWN keys to move through records incrementally. If many records have been saved, you can press and hold the UP or DOWN keys to scroll through the records more quickly.
5. Pressing the PRINT key will send the memory to the serial port.
6. Pressing the ZERO key will access the DELETE menu. (See figure 7b)
7. Press UP and DOWN to select the desired DELETE option.
 - If you select *NO* and press the ENTER key, the gauge will return to MEMORY page with no records deleted.
 - If you select *DELETE* and press the ENTER key, the gauge will delete the current saved record and return to MEMORY page.
 - If you select *DELETE ALL* and press the ENTER key, the gauge will delete ALL saved records and return to memory page.
8. Press the ESC key to return to Main Menu page.



Notice the number of records saved at the top right corner.
(This is record 3 of 3 total records saved)

Figure 7a Memory Menu

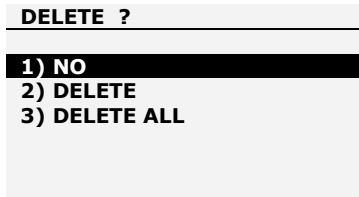

Figure 7b Memory Delete Menu

4) CALIBRATION This is used by service technicians when calibrating the gauge. Contact your Nextech distributor for details.

5) DIAGNOSTIC This is used to check status of the load cell. If you suspect that your load cell transducer has sustained an overload it is possible to check the status of the load cell immediately.

1. Place the gauge horizontally on the flat level surface.
2. Press MENU to navigate to the Main Menu.
3. Use the UP and DOWN keys to highlight *DIAGNOSTIC*
4. Press the ENTER key to navigate to the *DIAGNOSTIC* menu.
5. Press THE ESC to return to Main Menu.

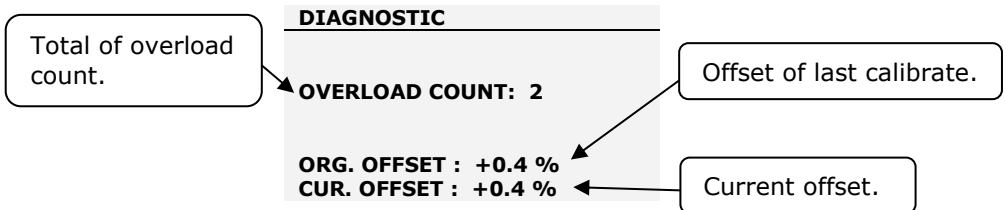

Figure 8 Diagnostic Menu

If the % offset is between 5% - 10 % please contact your supplier to arrange a recalibration of your gauge.

If the % offset is greater than 10% please contact your supplier to arrange for load cell replacement.

*These values are given as an indicator only – the need for calibration/repair may vary according to the individual characteristics of the load cell.

6) SELECT OUTPUT Use this menu to select between USB or PS/2 (RS232) Output. Select one of the two available options based on connection type. The default mode of the output port is USB output if no selection is made.

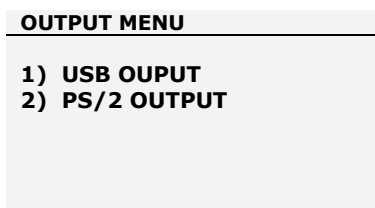

Figure 9 Output Menu

7) ABOUT This page shows information relevant to your gauge (Firmware revision, Model type, Gross maximum capacity, and Serial number).

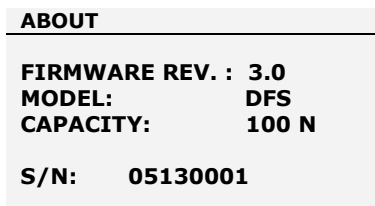

Figure 10 About Menu

Measurement Practice

For best measurement accuracy keep the compression/tension forces in line with the force gauge. Alleviate bending loads and torque loads applied to the load cell as these can adversely affect measurement performance.

Always keep the gauge below the capacity limit shown on the front of the gauge. If gauge is used above this capacity in either tension or compression, even for a short time, permanent load cell damage can result. Overload damage is not covered by warranty.

When you tare the force gauge to zero, the amount tared is part of the total force applied. So if you tare say 20% of the capacity you have 80% maximum force left you can apply.

For best performance and safety, use gauge with charged battery. Battery may degrade over time and result in reduce charged capacity. It is recommended that battery be replaced with genuine Nextech NiMH battery after few years in use or when re-calibration is performed. Battery NiMH type are safe and does not result in overheat when use with correct charger.

Calibration is performed from the factory and calibration certificate provided in the plastic case. Gauge should be re-calibrated approximately every 6 months but not more than 2 years. For assistance in calibration, please contact Nextech or Nextech's distributors.

DFS Specifications

Capacity and Divisions

Capacity (N)	mN	N	kN	g-f	kg-f	oz-f	lb-f
5	5000 x 1	5.000 x 0.001	-	509.8 x 0.1	0.5098 x 0.0001	17.980 x 0.005	1.1240 x 0.0002
10	10000 x 2	10.000 x 0.002	-	1019.6 x 0.2	1.0196 x 0.0002	35.96 x 0.01	2.2480 x 0.0005
20	20000 x 5	20.000 x 0.005	-	2039.0 x 0.5	2.0390 x 0.0005	71.92 x 0.02	4.496 x 0.001
50	-	50.00 x 0.01	-	5098 x 1	5.098 x 0.001	179.80 x 0.05	11.240 x 0.002
100	-	100.00 x 0.02	-	10196 x 2	10.196 x 0.002	359.6 x 0.1	22.480 x 0.005
200	-	200.00 x 0.05	-	20390 x 5	20.390 x 0.005	719.2 x 0.2	44.96 x 0.01
500	-	500.0 x 0.1	0.5000 x 0.0001	50985 x 5	50.98 x 0.01	1798.0 x 0.5	112.40 x 0.02
1000	-	1000.0 x 0.2	1.0000 x 0.0002	-	101.96 x 0.02	-	224.8 x 0.05
3000*	-	3000 x 1	3.000 x 0.001	-	305.9 x 0.1		674.4 x 0.2

**This model utilizes an external transducer.*

Accuracy: ± 0.2 % of rated capacity
 Operating temperature: 60 °F - 95 °F (15 °C - 35 °C)
 Temperature shift at zero load: ± 0.04 % of full-scale/°C

Output RS-232/USB: 8 data bits, 1 Start bit, 1 Stop bit, no parity
 Baud rate: 38400

Peak Capture Rate : 0.100 S
 ADC Sampling Rate : 4,000 Hz

Case Mounting: 4-M3 or 2-M5(10-32) to test stand or handle.
 Transducer mounting: M6 connecting to standard accessories, and to other grip or clamp.

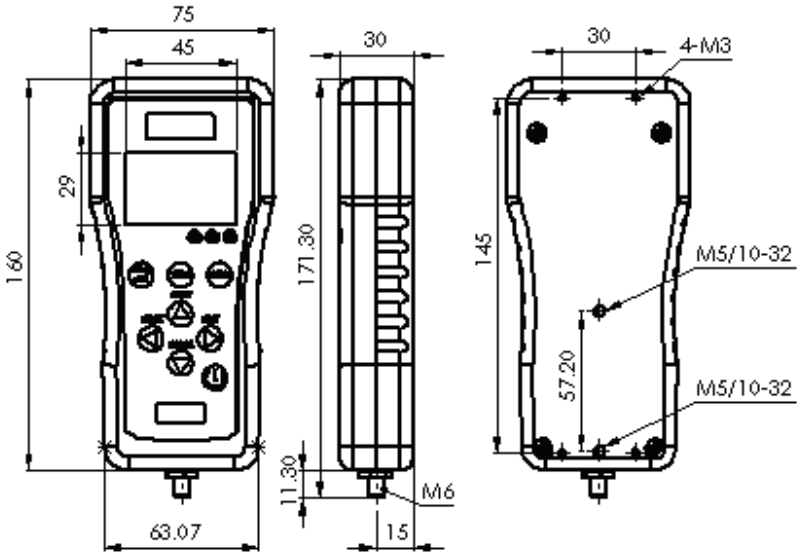

Conversion Factor

Unit	mN	N	kN	g-f	kg-f	oz-f	lb-f
mN	1	0.001	1e-6	101.97e-3	101.97e-6	3.597e-3	224.81e-6
N	1000	1	0.001	101.97	101.97e-3	3.597	224.81e-3
kN	1e6	1000	1	101.97e3	101.97	3597	224.81
g-f	9.807	9.807e-3	9.807e-6	1	0.001	35.28e-3	2.205e-3
Kg-f	9807	9.807	9.807e-3	1000	1	35.28	2.205
oz-f	278.01	0.27801	278.01e-6	28.345	28.345e-3	1	0.0625
lb-f	4448.2	4.4482	4.4482e-3	453.5	0.4535	16	1

NEXTECH®

NEXTECH GLOBAL CO.,LTD.
www.forcetorque.com